

SPECIFICATION FOR APPROVAL

REF. :

PROD. NAME	Line Filter	ABC'S DWG NO.	UF10□□□□□□L□-□□□		
		REV.	20140605-D	PAGE	1

I . Configuration and dimensions :

●UF10V2 Series

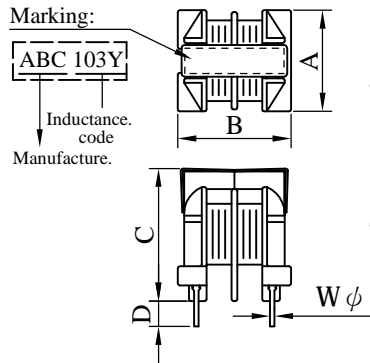

●UF10V4 Series

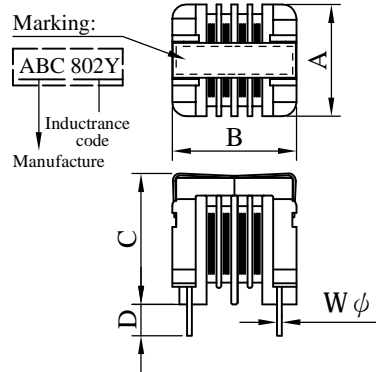

Unit : m/m

Series	A	B	C	D	E	F	W φ
UF10V2	17.0 max.	19.0 max.	22.5 max.	4.50 ±1.0	10.0±0.5	13.0 ±0.5	0.70
UF10V4	17.0 max.	19.0 max.	20.5 max.	4.50 ±1.0	10.0±0.5	13.0 ±0.5	0.70

II . Schematic diagram :

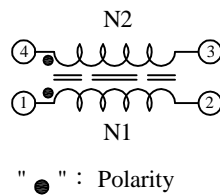

III . Description :

- a . Ferrite UU core construction.
- b . Enamelled copper wire : F class
- c . Product weight : 9.50g (ref.)
- d . Moisture sensitivity Level 1
- e . Products comply with RoHS' requirements
- f . Halogen free available

AR-001C

SPECIFICATION FOR APPROVAL

REF. :

PROD. NAME	Line Filter	ABC'S DWG NO.	UF10□□□□□□L□-□□□		
		REV.	20140605-D	PAGE	2

IV . General specification :

- a . Storage temp. : -40°C ~ +105°C
- b . Operating temp. : -25°C ~ +85°C
(Temp. rise included.)
- c . Pin strength : 1.0KG min.

V . Electrical characteristics :

DWG No.	L (mH) min.	RDC (Ω) max.	Rated Current (Aac)
UF10V2103YL□-□□□	10.0	2.5	0.4
UF10V2802YL□-□□□	8.0	1.7	0.5
UF10V2502YL□-□□□	5.0	1.0	0.7
UF10V2302YL□-□□□	3.0	0.5	0.8
UF10V2202YL□-□□□	2.0	0.4	1.0
UF10V2102YL□-□□□	1.0	0.2	1.6

- 1). Electrical specifications at 25°C
- 2). Temp. rise : 40°C max. at rated current

DWG No.	L (mH) min.	RDC (Ω) max.	Rated Current (Aac)
UF10V4802YL□-□□□	8.0	2.4	0.4
UF10V4502YL□-□□□	5.0	1.5	0.5
UF10V4402YL□-□□□	4.0	1.0	0.7
UF10V4252YL□-□□□	2.5	0.5	0.8
UF10V4162YL□-□□□	1.6	0.4	1.0
UF10V4801YL□-□□□	0.8	0.2	1.6

- 1). Electrical specifications at 25°C
- 2). Temp. rise : 40°C max. at rated current

VI . Curve :

●UF10V2 Series

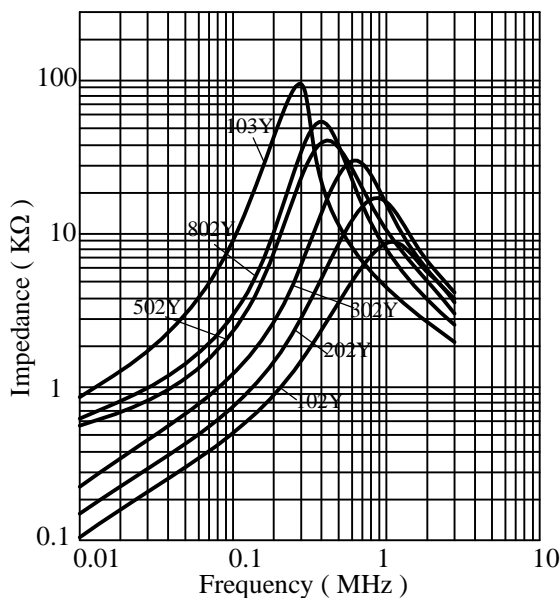

●UF10V4 Series

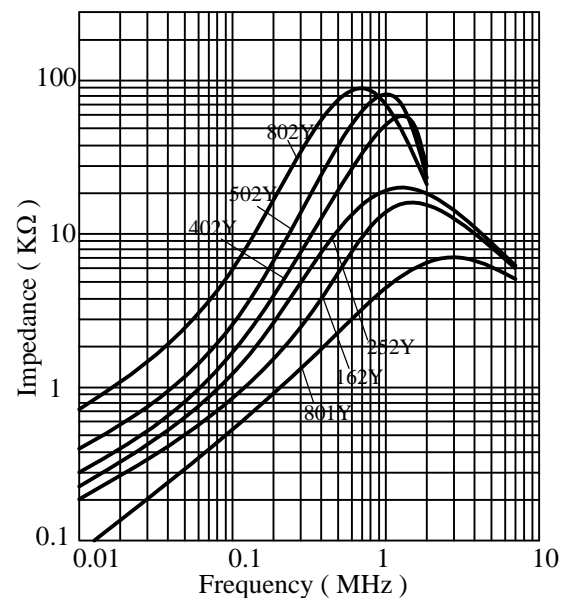

●Measuring Circuit :

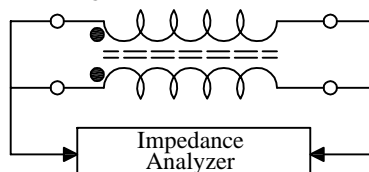

AR-001C

SPECIFICATION FOR APPROVAL

REF. :

PROD. NAME	Line Filter	ABC'S DWG NO.	UF10□□□□□□L□-□□□		
		REV.	20140605-D	PAGE	4

VIII . Reliability test :

Item	Reference documents	Test Condition	Test Specification
1.High Temperature Exposure	MIL-STD-202 Method 108	1.Temperature: 105℃ 2.Time:96 hours.	1.No mechanical and electrical damage. 2.Inductance shall not change more than ±50%.
2.Temperature Cycling	JESD22 Method JA-104	1.Temperature: -40℃ ~ 105℃ 2.Number of cycle:96 cycle 3.Dwell time:30 minutes	1.No mechanical and electrical damage. 2.Inductance shall not change more than ±50%.
3.Biased Humidity Test	MIL-STD-202 Method 103	1.Temperature:85±5 ℃ 2.Time:96 hours 3.Humidity: 85±5% RH.	1.No mechanical and electrical damage. 2.Inductance shall not change more than ±50%.
4.Operational Life	MIL-PRF-27	1.Temperature: 85℃ 2.Time:96 hours. 3.Apply rated current.	1.No mechanical and electrical damage. 2.Inductance shall not change more than ±50%.
5.External Visual	MIL-STD-883 Method 2009	Inspect product constructions, marking and workmanship.	1.No pollution on the surface of products. 2.Clear marking. 3.No crack.
6.Physical Dimensions	JESD22 Method JB-100	Verify physical dimensions to the applicable product detail specification.	Per product specification standard
7.Resistance to solvents	MIL-STD-202 Method 215	Immerse into solvent for 3±0.5 minutes & brush 10 times for 3 cycles.	1.No body change in apperance. 2.No marking blurred. 3.Inductance shall not change more than ±50%.
8.Vibration Test	MIL-STD-202 Method 204	1.Frequency and Amplitued : 10-2000-10 Hz, 1.5 mm. 2.Direction:X, Y, Z 3.Test duration:2 hours for each direction, 6 hours in total.	1.No mechanical and electrical damage. 2.Inductance shall not change more than ±50%.
9.Resistance To Soldering Heat Test	MIL-STD-202 Method 210	1.Method : Dip 2.Temperature : 260±5 3.Time (temp.≥ 260℃) : 10 second. 4.Number of times : 3 times.	1.No mechanical and electrical damage. 2.Inductance shall not change more than ±50%.
10.Rated current	MIL-STD-202 Method 330	Apply rated current for 5 second.	1.No mechanical and electrical damage. 2.Inductance shall not change more than ±50%.
11.Temperature rise	MIL-PRF-27	Apply rated current for 10 minutes.	1.No mechanical and electrical damage. 2.Inductance shall not change more than ±50%.
12.Over load	MIL-PRF-27	Apply double as rated current for 5 minutes. (It's not application to some special design)	1.No mechanical and electrical damage. 2.Inductance shall not change more than ±50%.
13.Solderability Test	J-STD-002	Dip pads in flux then dip in solder pot at 240±5 for 5 seconds.	Teminals area must have 95% min. Solder coverage.
14.Electrical Characteriazation	User Spec.	1.Operating temperature : -25℃~85℃ 2.Room temperature : 25℃.	1.No mechanical and electrical damage. 2.Inductance shall not change more than ±50%.
15.Withstanding Voltage Test	MIL-STD-202 Method 201	1.DC:500V 2.Time:1minutes	1.During the test no breakdown. 2.The characteristic is normal after test.
16.Drop	JESD22-B111	Packaged & Drop down from 1m.In 1 angle Iridges & 2 surfaces orientation.	1.No case deformation or change in appearance. 2.Inductance shall not change more than ±50%.
17.Terminal Strength Test	JIS-C-6429	1.Apply push force to samples mounted on PCB. 2.Force of 1.8 kg for 60±1 seconds.	After test, inductors shall be no mechanical damage.

AR-001C