

CUSTOMER :

SPEC NO.	ST-1206
DATE	19-Jun-12

RoHS Compliant

SPECIFICATIONS

Product

Description: Common Mode Choke Coil

Part Number PWC1206ST Series

Customer

Part Number : _____

【For Customer approval Only】

Date:

Approved By	Verified By	Rechecked By	Checked By

Approved By	Verified By	Prepared By
ISKANDAR NG	SHIKIN	SHIKIN



千如電子集團

ABC ELECTRONICS GROUP

FACTORY:

Lot 2, Jalan 6/2, Kawasan Perusahaan Seri Kembangan No.422, Sec 1, Yangfu Rd.,

43300, Seri Kembangan. Selangor Darul Ehsan

Malaysia.

Tel : 603-89422111 Fax : 603-89425888

HEAD QUARTERS:

Yangmei 32662 Taoyuan, Taiwan

Tel:886-3-478-8188

Fax:886-3-475-5503

CHIP COMMON MODE CHOKE COIL PWC SERIES

Introduction

This specification is applicable to chip type wire wounded common mode chokes. The PWC series are widely used in notebook, PC, USB, HUB, etc. The wire wound features advance in lower DC resistance and higher current tolerance, and much stable performance.

Features

- * Operating temperature -55°C to +125°C.
- * Excellent solderability and resistance to soldering heat.
- * Suitable for flow and reflow soldering.
- * Good dimensions, high reliability, and easy surface mount assembly.

Part Number

<u>PWC</u>	<u>1206</u>	<u>S</u>	<u>T</u>	<u>900</u>	<u>S</u>	<u>□</u> <u>□</u>
(1)	(2)	(3)	(4)	(5)	(6)	(7)

- (1) Chip Common Mode Choke Coil
- (2) Chip Size

CODE	L	W	H	UNIT
EIA	0.126	0.063	0.075	Inch
JIS	3.20	1.60	1.90	mm

- (3) General Characteristics
- (4) Taped In Reel. 2,000pcs/reel.
- (5) Typical Impedance at 100MHz
900 = 90Ω 161 = 160Ω 102 = 1000Ω
- (6) Tolerance
S = ± 25%
- (7) AOBA's Internal Code

Material Structure

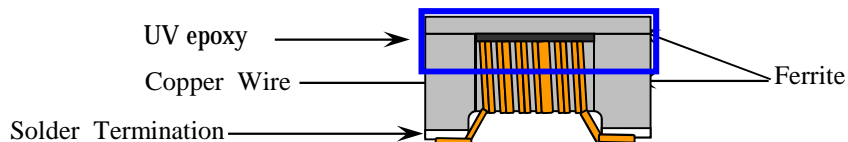

Reliability Specification

As attached.

**COMMON MODE CHOKE
WIRE WOUND TYPE**

PWC1206ST (3216) STANDARD SERIES

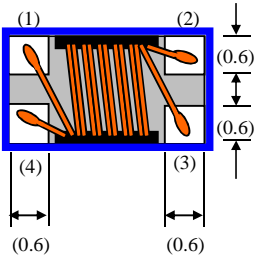
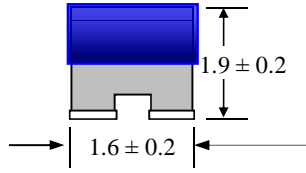
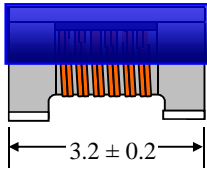

Remark : □ : Electrode
() : Reference Value
Unit: m/m

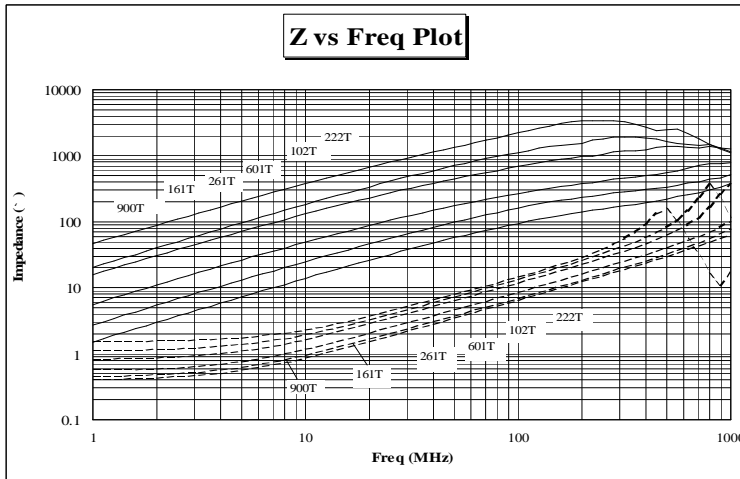
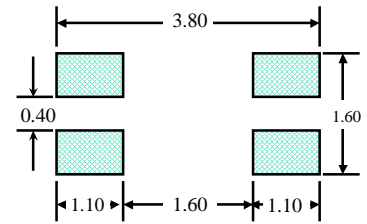

RECOMMENDED PCB PATTERN

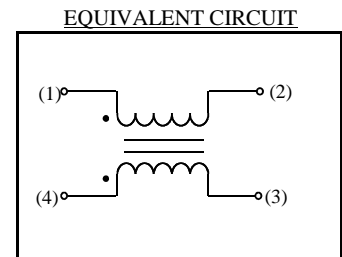

No Polarity

Specification

Part Number	Common Mode ¹ Impedance (Ω)	Rated Voltage V (DC)	Withstanding Voltage V (DC)	Rated ² Current max (mA)	DC Resistance max (Ω)	Insulation Resistance min (MΩ)
PWC1206ST900S	90	50	125	370	0.3	10
PWC1206ST161S	160	50	125	340	0.4	10
PWC1206ST261S	260	50	125	310	0.5	10
PWC1206ST601S	600	50	125	260	0.8	10
PWC1206ST102S	1000	50	125	230	1.0	10
PWC1206ST222S	2200	50	125	200	1.2	10

1. Impedance is measured in HP4287A at frequency of 100MHz.

2. For 15 °C rise.

COMMON MODE CHOKE

WIRE WOUND TYPE

RELIABILITY SPECIFICATION

1. Scope

This specification applies to wired wounded chip common mode choke of the following types used in electronic equipment :

Material : Ferrite

2. Construction

Configuration

& Dimension : Please refer to the attached figures and tables.

Terminals : PWC series shall consist of Ag followed by Nickel, then solder plating.

3. Operating Temperature Range

Operating Temperature Range is the scope of ambient temperature at which the common mode choke can be operated continuously at rated current.

Temp. Range : - 55 °C to + 125 °C

4. Recommended Soldering Conditions

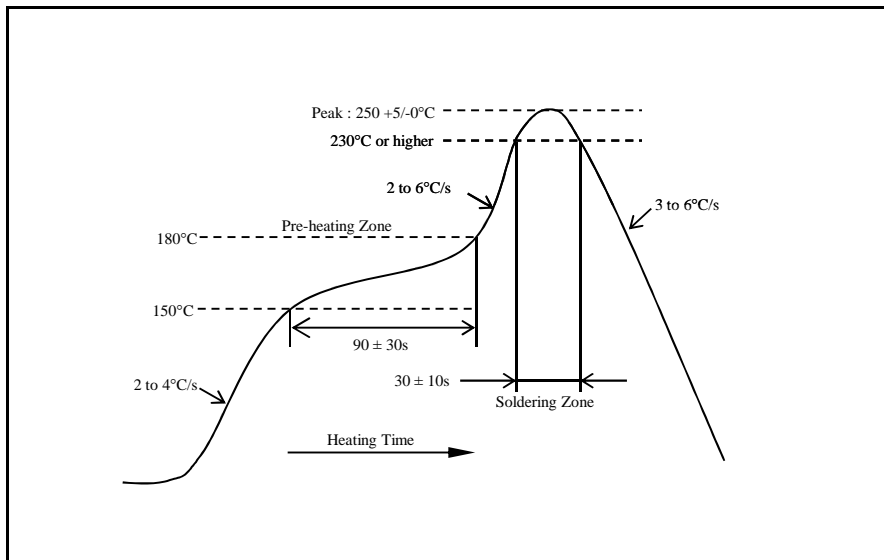

5 Characteristics

Standard Atmospheric Conditions

Unless otherwise specified, the standard range of atmospheric conditions for making measurements and tests are as follows :

Ambient Temperatur : 25 °C (20 °C) ± 2 °C

Relative Humidity : 60% to 70% (RH)

Air Pressure : 86 Kpa to 106 Kpa

**COMMON MODE CHOKE
WIRE WOUND TYPE**

RELIABILITY SPECIFICATION

	ITEM	CONDITION	SPECIFICATION
Electrical Characteristics	Common Mode Impedance (Z_c) and Tolerance	Measuring Equipment : HP-4287A or equivalent. Measuring Frequency : $100 \pm 1\text{MHz}$ Measuring Temperature : $25 \pm 5^\circ\text{C}$ (Refer to Measurement Diagram)	Within $\pm 25\%$
	Insulation Resistance	Measuring Voltage : Rated Voltage Measuring Time : 1 minute max. (Refer to Measurement Diagram)	10 mega ohms minimum
	Dielectric Withstanding Voltage	Test Voltage : 2.5 times for Rated Voltage Time : 1 to 5 seconds. Charge current : 1mA max. (Refer to Measurement Diagram)	No damage occurs when the test voltage is applied.
	Rated Current	Test Current : Rated Current (Refer to Measurement Diagram)	Temperature Rise : $\leq 15^\circ\text{C}$
	DC Resistance (RDC)	Measured with current of 100mA max. In case of doubt, measured by four terminal method. (Refer to Measurement Diagram)	Within Specified Tolerance.
Mechanical Characteristics	Flexure Strength		<p>Table 1.</p> <p>Change In Appearance Without distinct damage</p> <p>Change In Common Mode Impedance: Within $\pm 20\%$</p> <p>Insulation Resistance: 10MΩ min</p> <p>Withstanding Voltage: No damaged</p>
	Drop Test	Components shall be dropped three times on a concrete or steel board at height of 1m naturally at any directions.	
	Vibration (Random)	Components shall be randomly vibrated at amplitude of 1.5mm and frequency of 10 - 55 Hz: 0.04 G / Hz, 1 minute at a period of 2 hours in each of the three mutually perpendicular directions.	
	Solderability	Dip pads in flux and then in a solder pot containing lead free solder at $240^\circ\text{C} \pm 5^\circ\text{C}$ for 5 seconds.	A minimum of 80% of the metalized area must be covered with new solder.
	Resistance to Soldering Heat	Preheat components at 80 to 120°C for 1 minute. Dip components into flux and then into a solder pot containing lead free solder at $260^\circ\text{C} \pm 5^\circ\text{C}$ for 5 ± 1 seconds. Then components are to be tested after 4-48 hours at room temperature.	Meet Table 1.
	Component Adhesion (Push Test)	Components shall be reflow soldered onto a P. C. Board ($240^\circ\text{C} \pm 5^\circ\text{C}$ for 20 seconds). Then a dynamometer force gauge shall be applied to any side of the component.	Components must withstand a minimum force of 1 Kg without any failure of the termination to component attachment.

**COMMON MODE CHOKE
WIRE WOUND TYPE**

RELIABILITY SPECIFICATION

	ITEM	CONDITION	SPECIFICATION
Endurance Characteristics	Cold Temperature Storage	Components shall be stored at temperature of $-55\text{ }^{\circ}\text{C} \pm 2\text{ }^{\circ}\text{C}$ for 1000 (+48 hours -0 hour). Then components shall be subjected to standard atmospheric conditions for 4-48 hours. After that, measurement shall be made.	<u>Table 1.</u> Change In Appearance Without distinct damage
	High Temperature Storage	Components shall be stored at temperature of $+125\text{ }^{\circ}\text{C} \pm 2\text{ }^{\circ}\text{C}$ for 1000 (+48 hours -0 hour). Then components shall be subjected to standard atmospheric conditions for 4-48 hour. After that, measurement shall be made.	Change In Common Mode Impedance: Within $\pm 20\%$
	Moisture Resistance	Components shall be stored in the chamber at $40\text{ }^{\circ}\text{C}$ at 90 - 95% R. H. for 1000 (+48 hours -0 hour). Then components are to be tested after 4-48 hours at room temperature.	Insulation Resistance: $10\text{M}\Omega$ min
	Temperature Cycle	Each cycle shall consist of 30 minutes at -55°C followed by 30 minutes at $+125^{\circ}\text{C}$ with a 10-15 minutes maximum transition time between temperature extremes. Test duration is 100 cycles, then components are to be tested after 4-48 hours at room temperature.	Withstanding Voltage: No damaged
	High Temperature With Loaded	Components shall be stored at temperature of $+125\text{ }^{\circ}\text{C} \pm 2\text{ }^{\circ}\text{C}$ for 1000 (+48 hours -0 hour) with rated current applied. Then components shall be subjected to standard atmospheric conditions for 4-48 hour. After that, measurement shall be made.	

**COMMON MODE CHOKE
WIRE WOUND TYPE**

RELIABILITY SPECIFICATION

Measurement Diagram

Terminal to be Tested

When measuring and supplying the voltage, the following terminal is applied.

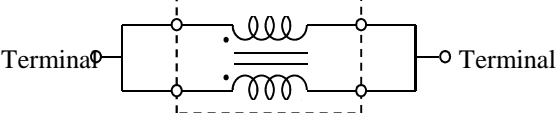
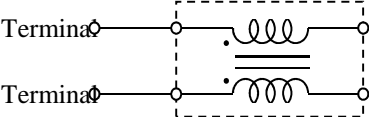
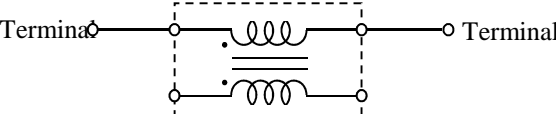
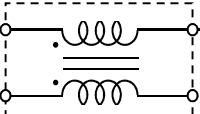
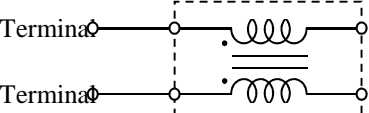
No.	Item	Terminal to be Tested
1	Common Mode Impedance (Measurement Terminal)	
2	Withstanding Voltage (Measurement Terminal)	
3	DC Resistance (Measurement Terminal	
4	Rated Current	
5	Insulation Resistance	

Packaging Information

Packing Quantity

Type	Pcs / Reel
PWC1206ST	2,000

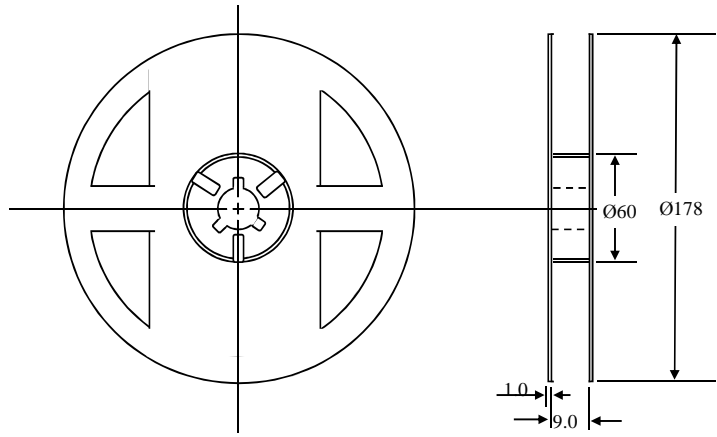

Dimensions (unit: m/m)

Type	Chip Cavity		Insert Pitch	Tape Thickness	
	A	B	F	K	T
PWC1206ST	1.88	3.50	4.00	2.10	0.20

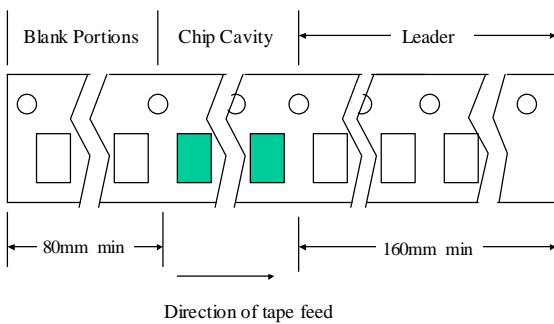
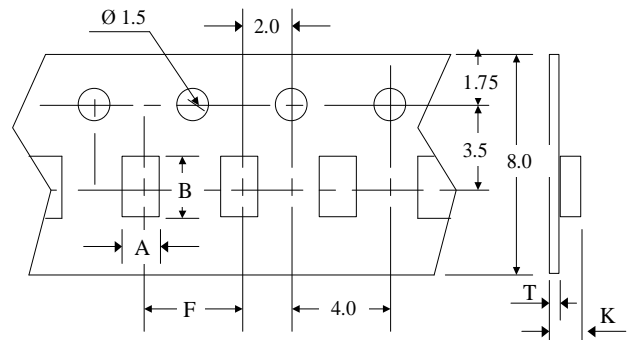

Top Tape Strength

The top tape requires a peel-off force of 0.2 to 0.7N in the direction of the arrow as illustrated below.

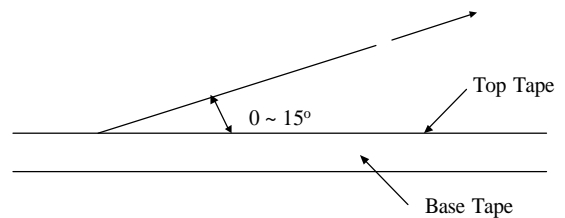

CHIP INDUCTOR SPECIFICATION

Operating Environment

Do not use this product under the following environmental conditions, on deterioration of performance, such as insulation resistance may result from the use.

1. In corrosive gases (acidic gases, alkaline gases, chlorine, sulfur gases, organic gases and etc.)
2. In the atmosphere where liquid such as organic solvent, may splash on the products.

Storage Condition

1. Storage period

Use the product within 12 months after delivered.

Solderability should be checked if this period is exceeded.

2. Storage environment conditions

- * Product should be store in the warehouse on the following conditions.

Temperature : -10 ~ +40°C

Humidity : 20 to 70% relative humidity. No rapid change on temperature and humidity.

- * Products should not be stored in corrosive gases, such as sulfurous, acid gases, alkaline gases, to prevent the following deterioration.

Poor solderability due to the oxidized electrode.

- * Products should be stored on the pallet for the prevention of the influence from humidity, dust and so on.

- * Products should be stored in the warehouse without heat shock, vibration, direct sunlight and so on.

- * Do not unpack the minimum package until immediately before use. After unpacking, re-seal promptly or store in desiccators with a desiccant.

Delivery

Care should be taken when transporting or handling product to avoid excessive vibration or mechanical shock.