

MESSRS. : \_\_\_\_\_

AGENT : \_\_\_\_\_

**SPECIFICATION  
of  
PYROELECTRIC PASSIVE  
INFRARED SENSOR**

MODEL NO. : PSH3-446-36AA

 **NIPPON CERAMIC CO., LTD.**

176-17 Hirooka, Tottori-shi, 689-1193 JAPAN  
TEL : +81-857-53-4666 FAX : +81-857-53-3532

APPROVED BY	CHECKED BY	DRAWN BY

MODEL NO. : PSH3-446-36AA	DRAWING NO.	REV :	PAGE	 <b>NIPPON CERAMIC CO., LTD.</b>
PART NO. :		A	1 / 11	

## 1. SCOPE

This specification describes a Pyroelectric Passive Infrared Sensor supplied by NIPPON CERAMIC CO.,LTD. for passive infrared sensor device.

## 2. TYPE of SENSOR

### 2.1. TYPE NAME

Pyroelectric Passive Infrared Sensor

### 2.2. MODEL NO.

PSH3-446-36AA

## 3. PHYSICAL CONFIGURATION AND DIMENSIONS

### 3.1. APPEARANCE

There are not remarkable wounds, spots, rust and etc.

### 3.2. DIMENSIONS

TO-5 Package : See Fig.1.

### 3.3. MARKING

Lot number and model number are marked on top surface of detector. (Figure.1)

#### 【Lot number】

To show last one digit of the A.D. year and week of the year of a inspection completion, Nicera Identification code.

Example : 4 26 B



#### 【Model number】

"PSH3" is marked.

## 4. GENERAL CHARACTERISTICS

Table.1

PARAMETER	SPECIFICATION
4.1. Pyroelectric Passive Infrared Sensor	Balanced differential type (Series opposed type )
4.2. Circuit Configuration	See Fig.3

## 5. ELECTRICAL CHARACTERISTICS

(ENVIRONMENT TEMPERATURE = 25 (+/-) 5 deg. C.)

Vdd = 3.3 V, unless specified.

Table.2

PARAMETER	CONDITION	SPECIFICATION
5.1. Maximum range(V)		-0.3 to 3.6 V
5.2. Supply Voltage(V)	Single Power Supply	2.7 to 3.6 V (Maximum rating : 3.6 V)
5.3. Fluctuation in Supply Voltage	Single Power Supply	Supply voltage (+/-) 3 %
5.4. Current Consumption	Vdd = 3.3V supply Circuit after Vout is not considered	Non-Detection : 20 uAmax.
5.5. Warm-up Time	*)Timing Chart : See Fig.2	Max. 30 sec.

MODEL NO. : PSH3-446-36AA	DRAWING NO.	REV : A	PAGE 2 / 11	 NIPPON CERAMIC CO., LTD.
PART NO. :				

5.6.	Dout update time	See Fig.5	Typ. 16 ms
5.7.	ADC Resolution		14 bits
5.8.	Output data format	See Fig.6	2 x 14 bits
5.9.	Sensitivity (S1,S2)	See Fig.4	Min. 1,260 $\mu$ V (180 counts) Typ. 1,715 $\mu$ V (245 counts) (7 $\mu$ V/count)
5.10.	Noise	Non-detection See Fig.4	Max. 350 $\mu$ V (50 counts) (7 $\mu$ V/count)
5.11.	ADC output offset		Typ. 8192 counts (7000...9200 counts)
5.12.	Gain Temperature	-20 $^{\circ}$ C to +70 $^{\circ}$ C	80 counts/K (Linearity: $\pm$ 5 %)

## 6. OPTICAL CHARACTERISTICS

Table.3

PARAMETER		SPECIFICATION
6.1.	Field of view	X,Y-axis : 132 deg. Z-axis : 146 deg.
6.2.	Filter substrate	Silicon
6.3.	Cut on (5 %T ABS)	5 (+/-) 1 micron
6.4.	Transmission	$\geq$ 70 % average 8 to 13 micron

## 7. ENVIROMENTAL REQUIREMENTS

Table.4

PARAMETER		SPECIFICATION
7.1.	Operating Temperature	-20 to +70 deg. C
7.2.	Storage Temperature	-30 to +80 deg. C
7.3.	Relative Humidity	The Sensor shall operate without increase in Noise Output when exposed to 90 to 95 % RH at 30 deg. C continuously
7.4.	Hermeticity	The Sensor shall be sealed to withstand a vacuum level of 21.28 kPa.
7.5.	Reliability Test	Specified in Appendix (10/10 Page).

## 8. RoHS COMPLIANCE

This product conforms to the RoHS Directive in force at the date of issuance of this Specification Sheet.

## 9. REVISION

Any revision of this specification should be made in writing by discussion.

MODEL NO. : PSH3-446-36AA	DRAWING NO.	REV : A	PAGE 3 / 11	 <b>NIPPON CERAMIC CO., LTD.</b>
PART NO. :				

## 10. NOTES

### 11.1. Design restrictions/precautions

If used for outdoor applications, be sure to apply suitable supplementary optical filter, drip-proof and anti-dew construction. This sensor is designed for indoor use.

In cases where secondary accidents due to operation failure or malfunctions can be anticipated, add a fail safe function to the design.

### 11.2. Usage restrictions/precautions

To prevent sensor malfunctions, operational failure or any deterioration of its characteristics, do not use this sensor in the following, or similar, conditions.

- A. In rapid environmental temperature changes.
- B. In strong shock or vibration.
- C. In a place where there are obstructing materials (Glass, Fog, etc.) through which infrared rays cannot pass within detection area.
- D. In fluid, corrosive gases and sea breeze.
- E. Continual use in high humidity atmosphere.
- F. Exposed to direct sun light or headlights of automobiles.
- G. Exposed to direct wind from a heater or air conditioner.

### 11.3. Assembly restrictions/precautions

#### Soldering

- A. Use soldering irons when soldering.
- B. Avoid keeping pins of this sensor hot for a long time as excessive heat may cause deterioration of its quality. (Ex. Within 5 sec. at 350 deg.C)

#### Washing

- A. Be sure to wash out all flux after soldering as remainder may cause malfunctions.
- B. Use a brush when washing. Washing with an ultrasonic cleaner may cause operational failure.

### 11.4. Handling and storage restrictions/precautions

To prevent sensor malfunctions, operational failure, appearance damage or any deterioration of its characteristics, do not expose this sensor to the following or similar, handling and storage conditions.

- A. Vibration for a long time.
- B. Strong shock.
- C. Static electricity or strong electromagnetic waves.
- D. High or Low temperature and humidity for a long time.
- E. Corrosive gases or sea breeze.
- F. Dirty and dusty environments that may contaminate the optical lens.

### 11.5. Restrictions on product use

The product described in this document shall not be used or embedded to any downstream products of which manufacture, use and / or sales are prohibited under any applicable laws and regulations.

Sensor troubles resulting from misuse, inappropriate handling or storage are not the manufacturer's responsibility.

MODEL NO. : PSH3-446-36AA	DRAWING NO.	REV : A	PAGE 4 / 11	 NIPPON CERAMIC CO., LTD.
PART NO. :				

Field of view

(Figure 1-a)



Top view

(Figure 1-b)

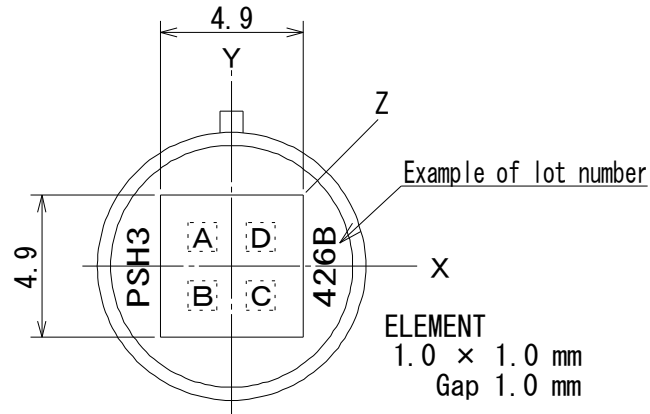

Side view

(Figure 1-c)

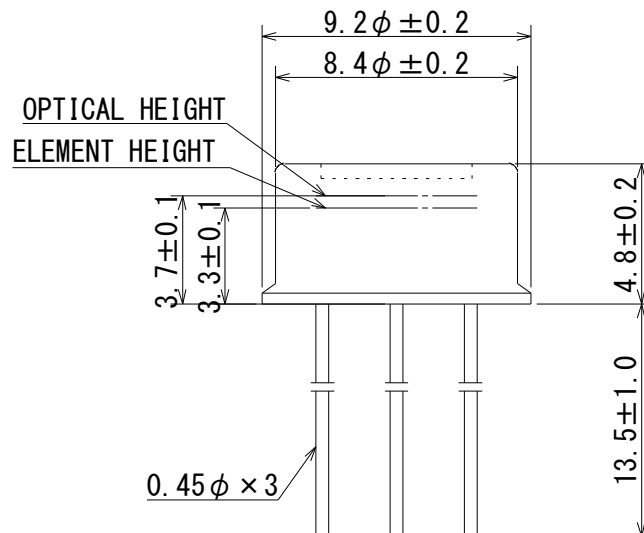

Base view

(Figure 1-d)

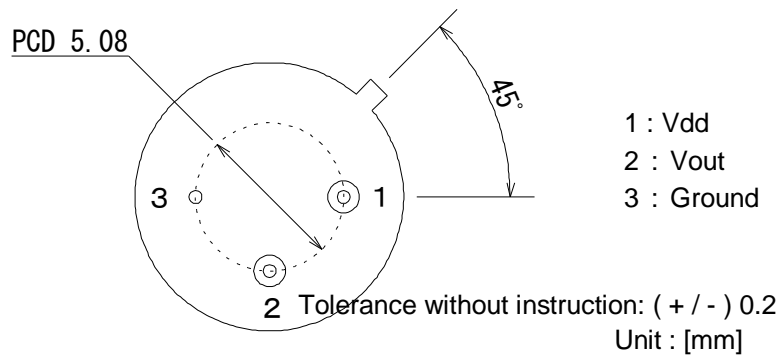

(\*)The sensor conforms to the standard for RoHS.

Fig.1 : Dimensions

MODEL NO. : PSH3-446-36AA	DRAWING NO.	REV : A	PAGE 5 / 11	NIPPON CERAMIC CO., LTD.
PART NO. :				

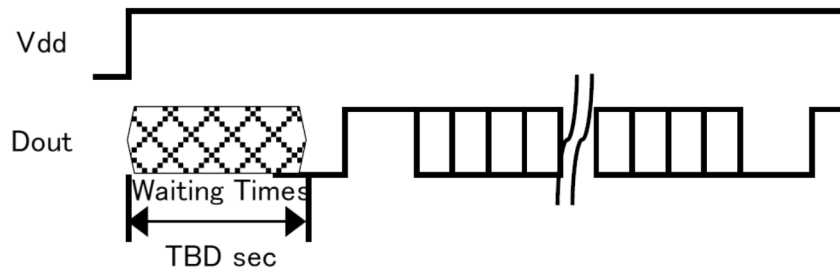

Cautions) Waiting (stability) Time: Max. 30 sec.  
 Regarding of detection or non-detection during the waiting time, ON signal may be made due to instability of circuit

Fig.2 : Warm-up Time

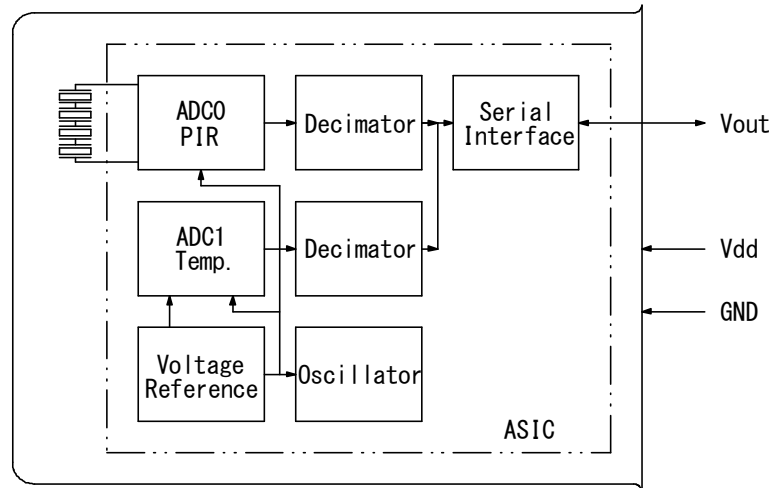

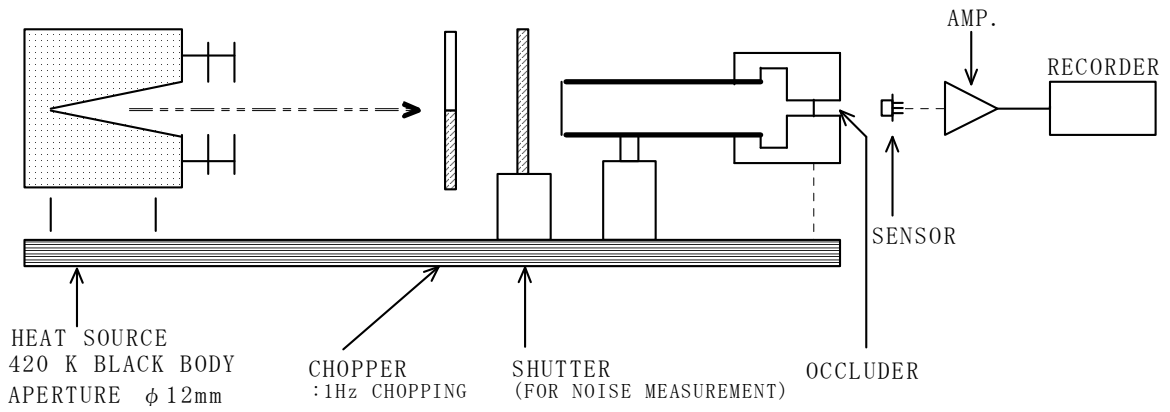

Fig.3 : Circuit Configuration

MODEL NO. : PSH3-446-36AA	DRAWING NO.	REV : A	PAGE 6 / 11	 NIPPON CERAMIC CO., LTD.
PART NO. :				



Occluder position

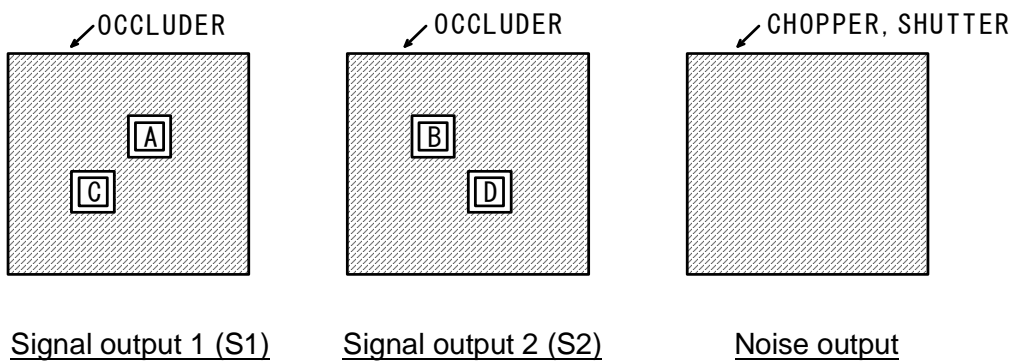

Fig.4 : Test set-up block diagram

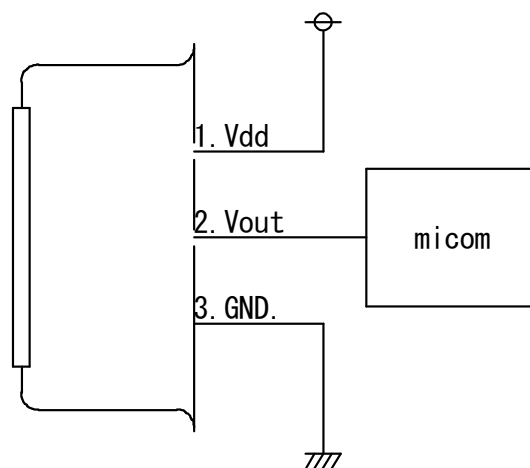

Fig.5 : Basic Application Circuit Examples

MODEL NO. : PSH3-446-36AA	DRAWING NO.	REV : A	PAGE 7 / 11	NIPPON CERAMIC CO., LTD.
PART NO. :				

## 11. DOUT INTERFACE

New data is transferred from the decimators to the serial interface every 32 system clocks, if the Dout output is not active (being read). If the microcontroller reads the register faster than the update rate of the filter, the data read is "0".

The Pyro generates an interrupt every 512 system clock cycles, if the microcontroller reads all 28 bits within 32 system clock cycles. The interrupt is indicated by the Pyro by pulling Dout high.

The microcontroller must wait for 1 $\mu$ s. It then generates a low to high transition on the Dout line, before it samples the data bit. The first bit read is the MSB. This process is repeated until all 28 bits have been read. After the last bit is read, the microcontroller must force low level and subsequently release Dout.

If reading is interrupted for more than 1 system clock with the Dout interface at low level, the output data latch is updated with new values. Reading can be interrupted, while the Dout interface is forced high. The output latch is not updated in this condition.

The Pyro accepts readout with microcontroller defined timing. The interrupt signal can be ignored and reading frequency can be up to FCLK/64. In this mode, the microcontroller has to force Dout to a high level for the duration of 3 device clock cycles (3/FCLK) and subsequently read out the data bits as described in the timing diagram below.

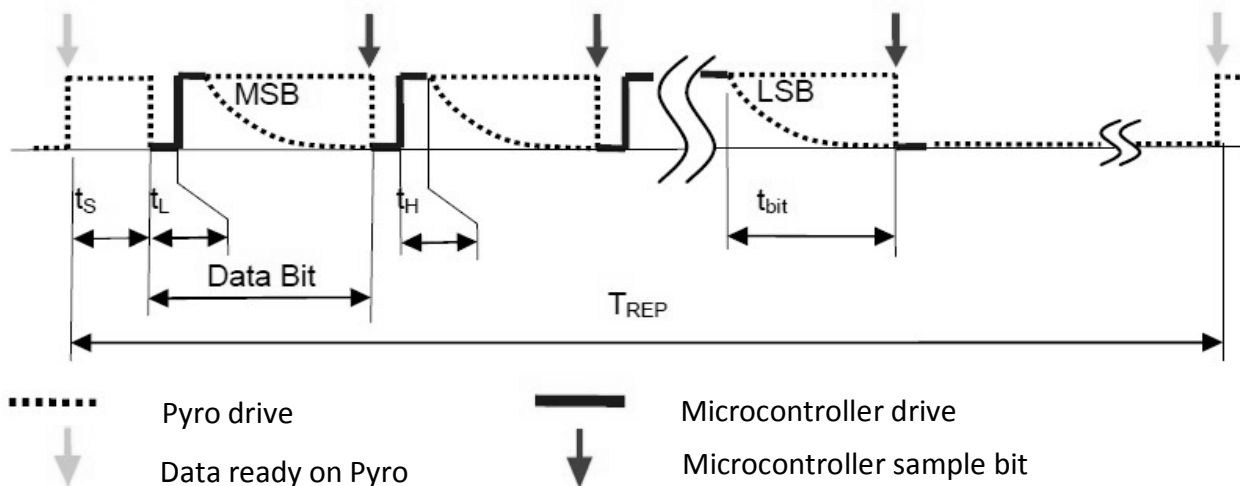

Fig.6 : Timing diagram for the Dout interface

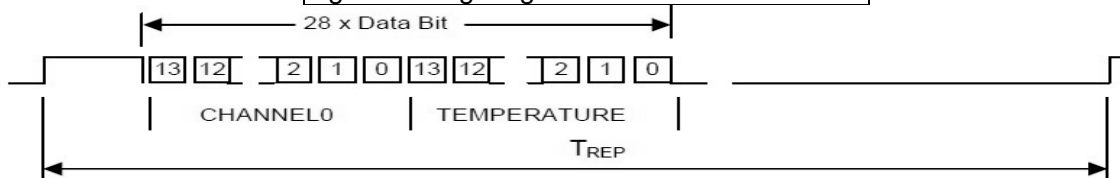

Fig.7 : Data words available on Dout interface

MODEL NO. : PSH3-446-36AA	DRAWING NO.	REV : A	PAGE 8 / 11	
PART NO. :				



## 12. ELECTRICAL CHARACTERISTICS

(ENVIRONMENT TEMPERATURE = 25°C.)

V<sub>dd</sub> = 3.3V

Parameter	Symbol	Min	Typ	Max	Unit	Remarks
Input low voltage	V <sub>IL</sub>			0.2V <sub>dd</sub>	V	
Input high voltage	V <sub>IH</sub>	0.8V <sub>dd</sub>			V	
Pull down current			200		uA	input to V <sub>dd</sub>
Pull up current			130		uA	input to GND
Data setup time	t <sub>s</sub>	2			1/F <sub>CLK</sub>	
Data clock low time	t <sub>L</sub>	200			ns	
Data clock high time	t <sub>H</sub>	200			ns	
Data bit settling time	t <sub>bit</sub>	1			us	C <sub>LOAD</sub> = 10pF
Dout update cycle	TREP		512		1/F <sub>CLK</sub>	
Dout low time	t <sub>L</sub> + t <sub>bit</sub>			1/F <sub>CLK</sub>		to avoid update
ADC Counts of bits			28		Bits	
ADC Resolution			14		Bits	Max Count = 2 <sup>14</sup> -1
ADC Sensitivity		6	6.5	7	uV/count	
ADC Temperature coefficient		-300		300	ppm/K	
ADC Offset		7000	8192	9200	Counts	
Gain temperature			80		Counts/K	-20°C to +90°C
Linearity of temperature		-5		5	%	-20°C to +90°C
Counts value at Ambient		5700	6700	7700	Counts	@25°C
Internal clock frequency	F <sub>CLK</sub>		32		kHz	
Temperature dependency		-1000		1000	ppm/K	-20°C to +70°C

To avoid saturation, the Pyro contains out of range detection logic, which detects values above 15872 (97% of range) and below 511 (3% of range).

If the values are outside this range, the input of the ADC is shorted for the duration of 512 system clocks.

MODEL NO. : PSH3-446-36AA	DRAWING NO.	REV : A	PAGE 9 / 11	
PART NO. :				

## Packaging specification

Refer to sketches below.

Inner package      Max. 200pcs./Sheet  
 Max. 400pcs./Box.

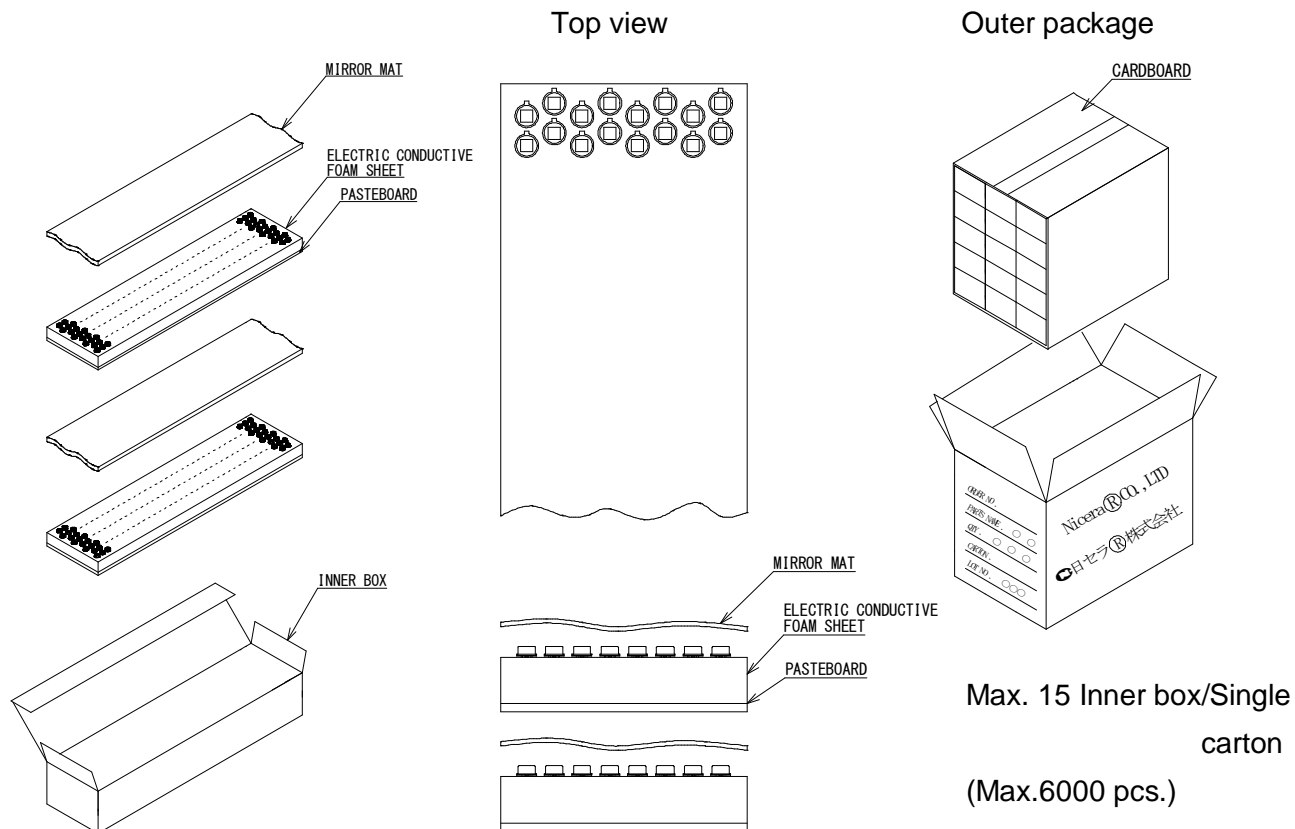

## Carton

The carton is closed with sticky tape and banded by plastic tie.

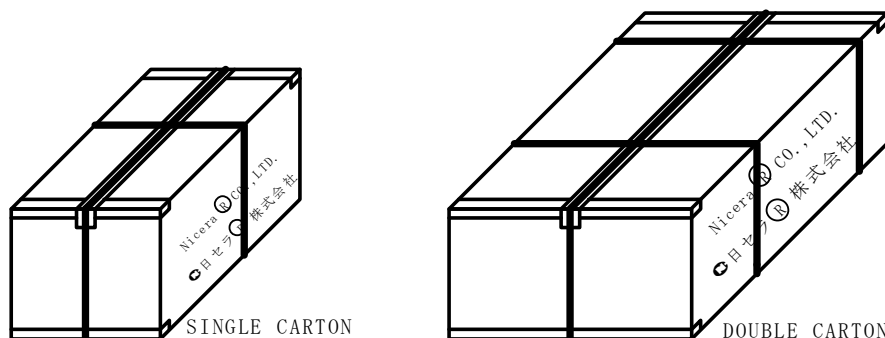

Max. 6,000 pcs./Single carton

Max.12,000 pcs./Double carton

MODEL NO. : PSH3-446-36AA	DRAWING NO.	REV : A	PAGE 10 / 11	
PART NO. :				

## Reliability Test

Test items	Test condition	Qty	Judgement conditions	Result	Judgement
1.High temperature storage test	JIS C 7021 B-10 75°C, 1000h	10	Change rate of sensor's signal output is within±20% compare with the default through the sensor's output detection by Nicer's blackbody furnace.	10/10pcs. OK	○
2.Low temerature storage test	JIS C 7021 B-12 -35°C, 1000h	10		10/10pcs. OK	○
3.High humidity / temperature storage test	JIS C 7021 B-11 Condition-B 60°C, 90%RH, 1000h	10		10/10pcs. OK	○
4.Heat cycle test	JIS C 7021 A-4 -35~75°C, 30min each., 10cycles	10		10/10pcs. OK	○
5.THB (temperature/ humidity bias) Test	JIS C 7021 B-11 Condition-B 60°C, 90%RH, 5VDC, 1000h	10		10/10pcs. OK	○
6.Solder heat test	JIS C7021 A-1 ①260 °C±3°C, 10±1sec. ( Condition-Auto flow soldering) ②380°C±10°C, 3±1sec. ( Condition-Hand soldering)	5		5/5pcs. OK	○
7.Solderability test	JIS C7021 A-2 ①Sn-Cu,245°C±2°C,3sec. ②Sn-3.0Ag-0.5Cu,245°C±2°C,3sec.	5	Change rate of sensor's signal output is within±20% compare with the default through the sensor's output detection by Nicer's blackbody furnace.	5/5pcs. OK+Appearance OK	○
			Over 95% of solder adhere on terminal area.	5/5pcs. OK+Appearance OK	○
8.Electrostatic Discharge (MM method)	EIA/ JESD22-A115-A C=200pF, R=0ohm, Applying 1 time	5	Confirmation of discharge voltage value (Withstand Voltage) within ±10% output behavior characteristic change rate in before and after voltage impression	5/5pcs. Drain:+500V, -500V 5/5pcs. Source:+500V, -500V	(Check for withstand voltage level )
9.Variable frequency vibration test	JIS C7021 A-10 Condition-A 10~55~10Hz/min., amplitude 1.5mm, X,Y,Zaxial direction/2h each.	5	Change rate of sensor's signal output is within±20% compare with the default through the sensor's output detection by Nicer's blackbody furnace.	5/5pcs. OK	○
10.Drop test	JIS C 7021 A-8 Height 750mm, Board(15*15*3cm), Drop for 3times	5		5/5pcs. OK	○
11.Tensile strength test	JIS C 5402 6.26.3 Lead 19.6N for 5sec.	5		5/5pcs. OK	○

### 【Reliability Test Judgement Conditions】

#### 1-1 Performance Spec

##### 1-1-1 Signal output

Pass with under 20% change rate compare with the default.

##### 1-1-2 Noise Output

Pass with fulfill the standard of dark-field white noise in normal temperature(25±5°C)

#### 1-2 Structure Spec (Appearance)

No remarkable damage ,pollution, rust etc.

MODEL NO. : PSH3-446-36AA	DRAWING NO.	REV : A	PAGE 11 / 11	
PART NO. :				