

CLASSIFICATION	PRODUCT SPECIFICATION	No. DS-17xx-2400-102	REV. 2.0
SUBJECT	CLASS 2 BLUETOOTH LOW ENERGY SINGLE MODE MODULE	PAGE	1 of 35
CUSTOMER'S CODE PAN172x / PAN171x	PANASONIC'S CODE ENW89820AxKF / ENW89835AxKF	DATE	16.12.2013

Specification for Production

Applicant / Manufacturer Panasonic Industrial Devices Europe GmbH
Hardware Zeppelinstrasse 19
 21337 Lüneburg
 Germany

Applicant / Manufacturer Please refer to chapter 25 / 25.1 Information regarding
Software Software Versions

Software Version Please refer to chapter 25 / 25.1 Information regarding
 Software Versions

By purchase of any of products described in this document the customer accepts the document's validity and declares their agreement and understanding of its contents and recommendations. Panasonic reserves the right to make changes as required without notification.

Power Electronics R&D Center Wireless Connectivity Panasonic Industrial Devices Europe GmbH	APPROVED genehmigt	CHECKED geprüft	DESIGNED erstellt
---	-----------------------	--------------------	----------------------

CLASSIFICATION	PRODUCT SPECIFICATION	No. DS-17xx-2400-102	REV. 2.0
SUBJECT	CLASS 2 BLUETOOTH LOW ENERGY SINGLE MODE MODULE	PAGE	2 of 35
CUSTOMER'S CODE PAN172x / PAN171x	PANASONIC'S CODE ENW89820AxKF / ENW89835AxKF	DATE	16.12.2013

TABLE OF CONTENTS

1.	Scope of this Document.....	4
2.	Difference PAN1720 / PAN1721	4
3.	Difference PAN172x / PAN171x	4
4.	Key Features.....	4
5.	Bluetooth Low Energy	6
6.	Applications for the Module.....	6
7.	Description for the Module	6
8.	Detailed Description.....	7
	8.1. PAN172x Terminal Layout.....	7
	8.2. Crossreference GPIO PAN-Module to BlueRadios-Module	9
9.	Bluetooth Features.....	10
10.	PAN172x Block Diagram.....	10
11.	Test Conditions	11
12.	General Device Requirements and Operation	11
	12.1. Absolute Maximum Ratings	11
	12.2. Recommended Operating Conditions.....	11
	12.3. PAN1720 Current Consumption	12
13.	Bluetooth RF Performance.....	13
	13.1. PAN1720 Bluetooth Characteristics	13
	13.2. PAN1721 Bluetooth Characteristics	13
	13.3. PAN17XX Spurious Emission.....	13
14.	Soldering Temperature-Time Profile (for reflow soldering)	14
	14.1. For lead solder	14
	14.2. For leadfree solder.....	14
15.	PAN172x Module Dimension	15
16.	PAN171x Module Dimension	16
17.	PAN172x FootPrint of the Module.....	17
18.	PAN171x FootPrint of the Module.....	18
19.	Case Marking	19
	19.1. Example for Marking.....	19
	19.2. Marking Definition	19
20.	Mechanical Requirements.....	19
21.	Development of Applications.....	20
22.	Reliability Tests	20
23.	Cautions	20
	23.1. Design Notes	20
	23.2. Installation Notes	21
	23.3. Usage Conditions Notes	21
	23.4. Storage Notes.....	22

CLASSIFICATION	PRODUCT SPECIFICATION	No. DS-17xx-2400-102	REV. 2.0
SUBJECT	CLASS 2 BLUETOOTH LOW ENERGY SINGLE MODE MODULE	PAGE	3 of 35
CUSTOMER'S CODE PAN172x / PAN171x	PANASONIC'S CODE ENW89820AxKF / ENW89835AxKF	DATE	16.12.2013

23.5. Safety Cautions	22
23.6. Other cautions	22
24. Packaging	24
24.1. PAN172x Tape Dimension	24
24.2. PAN171x Tape Dimension	25
24.3. Packing in Tape	26
24.4. Component Direction	26
24.5. Reel Dimension	27
24.6. Label for Package.....	28
24.7. Total Package.....	28
25. Ordering Information	29
25.1. Information regarding Software Versions	29
26. RoHS and REACH Declaration.....	30
27. Data Sheet Status	31
28. History for this Document.....	31
29. Related Documents.....	31
30. General Information	32
31. Regulatory Information.....	32
31.1. FCC Notice	32
31.2. Caution	32
31.3. Labeling Requirements.....	33
31.4. Antenna Warning	33
31.5. Approved Antenna List	33
31.6. RF Exposure PAN17xx.....	33
32. Industry Canada Certification.....	34
32.1. IC Notice	34
32.2. Labeling Requirements.....	34
33. Bluetooth Certification.....	34
34. European R&TTE Declaration of Conformity	35
35. Life Support Policy	35

CLASSIFICATION	PRODUCT SPECIFICATION	No. DS-17xx-2400-102	REV. 2.0
SUBJECT	CLASS 2 BLUETOOTH LOW ENERGY SINGLE MODE MODULE	PAGE	4 of 35
CUSTOMER'S CODE PAN172x / PAN171x	PANASONIC'S CODE ENW89820AxKF / ENW89835AxKF	DATE	16.12.2013

1. SCOPE OF THIS DOCUMENT

This product specification applies to Panasonic's, Class 2, Bluetooth®¹ low energy single mode module, series number: PAN1720 ([CC2540 from Texas Instruments](#)) and PAN1721 ([CC2541 from Texas Instruments](#)).

2. DIFFERENCE PAN1720 / PAN1721

Both the PAN1720 and PAN1721 are referred to as the PAN172x in this document.

The PAN1721 is pin-compatible with the PAN1720, with the exception that USB is the hardware communication interface on the PAN1720 and I2C is the hardware communication interface on the PAN1721. Compared to the PAN1720, the PAN1721 provides lower RF current consumption. The PAN1721 does not have the USB interface found on the PAN1720, and provides lower maximum output power in TX mode.

Additional details, which have an impact on the module can be found in the datasheets from Texas Instruments.

[CC2540 from Texas Instruments](#)

[CC2541 from Texas Instruments](#)

Both ICs the CC2540 as well as the CC2541 come with an internal 256 KB flash memory.

3. DIFFERENCE PAN172X / PAN171X

The PAN171x are the non antenna version where the PAN172x are the versions with antenna.

4. KEY FEATURES

- Bluetooth Low Energy Single Mode 4.0
- Surface mount type 15.6 x 8.7 x 1.8 mm³
- Up to 4.0 dBm Tx power (typical) with transmit power control
- CC2541 has typically 0dBm Tx power
- High sensitivity (-94 dBm typ.)
- Texas Instrument's CC2540/CC2541 Single Chip BLE Solution inside
- High performance low power 8051 Microcontroller core
- No external components needed
- Fast Connection Setup
- Internal crystal oscillator (32MHz)
- Internal 32khz crystal oscillator for Sleep Timer
- Two powerful USARTs
- UART, USB or I2C interface
- Powerful five channel DMA

¹ Bluetooth is a registered trademark of the Bluetooth Special Interest Group.

CLASSIFICATION	PRODUCT SPECIFICATION	No. DS-17xx-2400-102	REV. 2.0
SUBJECT	CLASS 2 BLUETOOTH LOW ENERGY SINGLE MODE MODULE	PAGE	5 of 35
CUSTOMER'S CODE PAN172x / PAN171x	PANASONIC'S CODE ENW89820AxKF / ENW89835AxKF	DATE	16.12.2013

- Latest Profiles included e.g. Battery Monitor and Temperature sensor
- Integrated shielding to resist EMI
- Manufactured in conformance with RoHS

CLASSIFICATION	PRODUCT SPECIFICATION	No. DS-17xx-2400-102	REV. 2.0
SUBJECT	CLASS 2 BLUETOOTH LOW ENERGY SINGLE MODE MODULE	PAGE	6 of 35
CUSTOMER'S CODE PAN172x / PAN171x	PANASONIC'S CODE ENW89820AxKF / ENW89835AxKF	DATE	16.12.2013

5. BLUETOOTH LOW ENERGY

Bluetooth Low Energy (BLE), part of Bluetooth Ver. 4.0, specifies two types of implementation: Single mode and dual mode. Single mode devices implement the low energy specification and consume just a fraction of the power of classic Bluetooth, allowing the short-range wireless standard to extend to coin cell battery applications for the first time. Dual mode devices combine low energy with the power of classic Bluetooth and are likely to become a de facto feature in almost all new Bluetooth enabled cellular phones and computers.

Single mode Bluetooth 4.0 Low Energy is not backwards compatible with previous Bluetooth standards. Dual mode Bluetooth 4.0 Low Energy is backwards compatible and well suited for gateway applications, but is not practical for low power devices.



6. APPLICATIONS FOR THE MODULE

All Embedded Wireless Applications

- Access Points
- Industrial Control
- Medical
- Scanners
- Wireless Sensors
- Low Power
- Proximity
- Smart Phone
- Access Points
- Temperature
- Wellness
- Sports

7. DESCRIPTION FOR THE MODULE

The PAN172x is a short-range, Class 2, BLE single mode module for implementing Bluetooth functionality into various electronic devices. A block diagram can be found in chapter 10.

The PAN172x is a cost-effective, low-power, true system-on-chip (SoC) for Bluetooth low energy applications. It enables robust BLE master or slave nodes to be built with very low total bill-of-material costs. The PAN172x combines an excellent RF transceiver with an industry-standard enhanced 8051 MCU, in-system programmable flash memory, 8-KB RAM, and many other powerful supporting features and peripherals. The PAN172x is suitable for systems where very low power consumption is required. Very low-power sleep modes are available. Short transition times between operating modes further enable low power consumption.

Panasonic offers Bluetooth low energy protocol stacks and applications from Texas Instruments and BlueRaidios. The Bluetooth low energy protocol stack from Texas Instruments, is a flexible and cost-effective single-mode Bluetooth low energy solution.

The BlueRaidios stack enables rapid and low cost development using an AT command set without the need for a compiler. Additional advantages include UART programming, over-the-air-updates, easy integration "C" library framework, serial streaming of data, and smart phone libraries and applications.

CLASSIFICATION	PRODUCT SPECIFICATION	No. DS-17xx-2400-102	REV. 2.0
SUBJECT	CLASS 2 BLUETOOTH LOW ENERGY SINGLE MODE MODULE	PAGE	7 of 35
CUSTOMER'S CODE PAN172x / PAN171x	PANASONIC'S CODE ENW89820AxKF / ENW89835AxKF	DATE	16.12.2013

Refer to [1] PAN172xETU Design-Guide and chapter 25 Ordering Information.

Please contact your local sales office for further details on additional options and services:

www.panasonic.com/rfmodules for the US,

http://industrial.panasonic.com/eu/i/29606/wireless_modules/wireless_modules.html for EU

or write an e-mail to wireless@eu.panasonic.com.

8. DETAILED DESCRIPTION

8.1. PAN172X TERMINAL LAYOUT

PAN17x1 I2C pins are marked with a blue circle.

PAN171x antenna pin is marked with a blue circle.

Top View, Application PCB

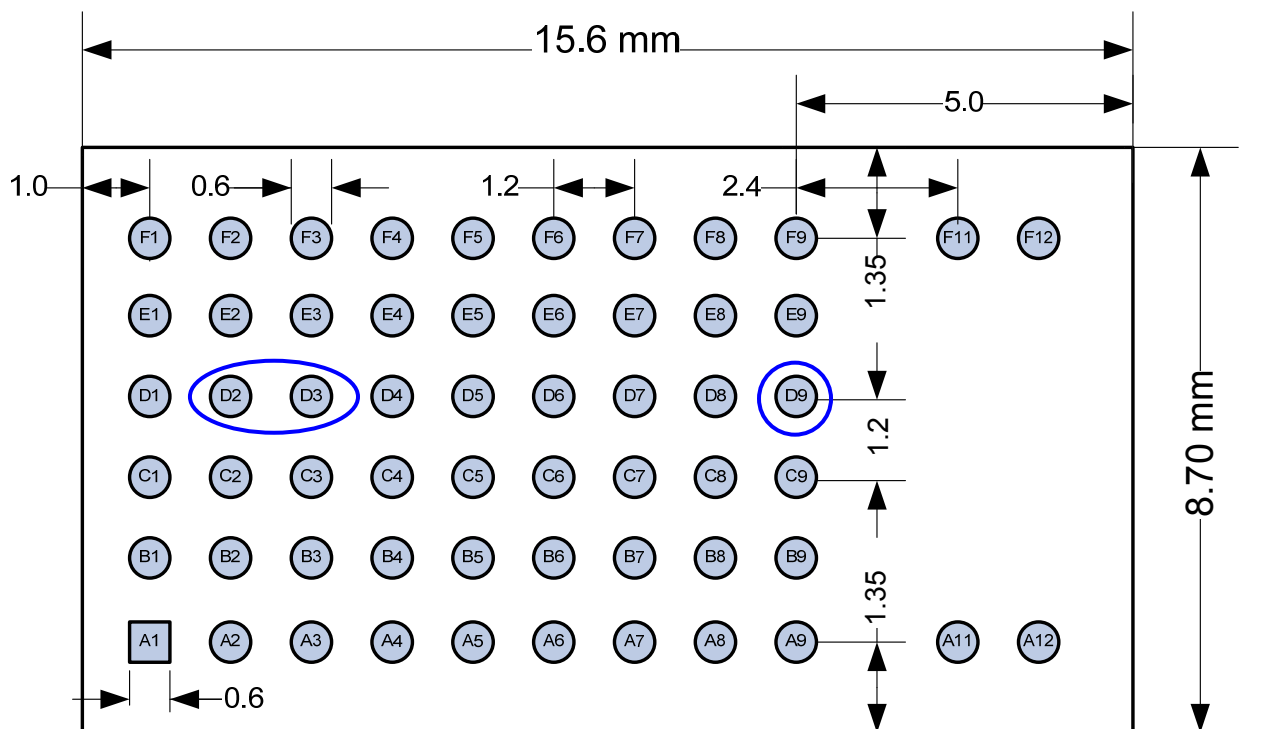

CLASSIFICATION	PRODUCT SPECIFICATION	No. DS-17xx-2400-102	REV. 2.0
SUBJECT	CLASS 2 BLUETOOTH LOW ENERGY SINGLE MODE MODULE	PAGE	8 of 35
CUSTOMER'S CODE PAN172x / PAN171x	PANASONIC'S CODE ENW89820AxKF / ENW89835AxKF	DATE	16.12.2013

No	Pin Name	Pin Type	Description
A1	GND	Ground Pin	Connect to Ground
A2	P1.0	Digital I/O	Port 1.0 – 20mA drive capability
A3	Reset	Digital Input	Reset, active-low
A4	VCC	Power	2V – 3.6V analog/digital power supply connection
A5	VCC	Power	2V – 3.6V analog/digital power supply connection
A6	VCC	Power	2V – 3.6V analog/digital power supply connection
A7	GND	Ground Pin	Connect to Ground
A8	NC		Not Connected
A9	GND	Ground Pin	Connect to Ground
A11	GND	Ground Pin	Connect to Ground
A12	GND	Ground Pin	Connect to Ground
B1	P1.3	Digital I/O	Port 1.3
B2	P1.2	Digital I/O	Port 1.2
B3	P1.1	Digital I/O	Port 1.1 – 20mA drive capability
B4	P0.6	Digital I/O	Port 0.6
B5	NC		Not Connected
B6	P0.1	Digital I/O	Port 0.1
B7	P0.0	Digital I/O	Port 0.0
B8	NC		Not Connected
B9	NC		Not Connected
C1	NC		Not Connected
C2	P1.4	Digital I/O	Port 1.4 / BR-SW UART CTS
C3	P1.5	Digital I/O	Port 1.5 / BR-SW UART RTS
C4	P0.7	Digital I/O	Port 0.7
C5	NC		Not Connected
C6	NC		Not Connected
C7	NC		Not Connected
C8	GND	Ground Pin	Connect to Ground
C9	GND	Ground Pin	Connect to Ground
D1	DVDD_USB	Power (digital)	2V – 3.6V digital power supply connection
D2	USB_N	Digital I/O	USB N / PAN17x1 I2C SDA // Leave floating if not used.
D3	USB_P	Digital I/O	USB P / PAN17x1 I2C SCL // Leave floating if not used.
D4	NC		Not Connected
D5	NC		Not Connected
D6	NC		Not Connected
D7	GND	Ground Pin	Connect to Ground
D8	GND	Ground Pin	Connect to Ground
D9	NC/RF		PAN172x Not Connected/50 ohm RF_Out PAN171x
E1	P2.1/DD	Digital I/O	Port 2.1 / Programming Interface DD
E2	P2.2/DC	Digital I/O	Port 2.2 / Programming Interface DC
E3	DGND_USB	Ground Pin	Connect to Ground
E4	NC		Not Connected
E5	NC		Not Connected
E6	P0.2/RX/MISO	Digital I/O	Port 0.2 / TI-SW UART RX / SPI MISO
E7	NC		Not Connected
E8	GND	Ground Pin	Connect to Ground
E9	GND	Ground Pin	Connect to Ground
F1	GND	Ground Pin	Connect to Ground
F2	P1.6	Digital I/O	Port 1.6 / BR-SW UART TX
F3	P1.7	Digital I/O	Port 1.7 / BR-SW UART RX
F4	P2.0	Digital I/O	Port 2.0
F5	P0.4/CTS/CS	Digital I/O	Port 0.4 / TI-SW UART CTS / SPI CS
F6	NC		Not Connected
F7	P0.3/TX/MOSI	Digital I/O	Port 0.3 / TI-SW UART TX /SPI MOSI
F8	P0.5/RTS/CLK	Digital I/O	Port 0.5 / TI-SW UART RTS /SPI CLK
F9	GND	Ground Pin	Connect to Ground
F11	GND	Ground Pin	Connect to Ground
F12	GND	Ground Pin	Connect to Ground

CLASSIFICATION	PRODUCT SPECIFICATION	No. DS-17xx-2400-102	REV. 2.0
SUBJECT	CLASS 2 BLUETOOTH LOW ENERGY SINGLE MODE MODULE	PAGE	9 of 35
CUSTOMER'S CODE PAN172x / PAN171x	PANASONIC'S CODE ENW89820AxKF / ENW89835AxKF	DATE	16.12.2013

8.2. CROSSREFERENCE GPIO PAN-MODULE TO BLUERADIOS-MODULE

PAN17xx-BR		BlueRadios	
No	Pin Name	No	Pin Name
B7	P0.0	21	ADC_0
B6	P0.1	4	ADC_1
E6	P0.2 / MISO	5	SPI_MISO
F7	P0.3 / MOSI	8	SPI_MOSI
F5	P0.4 / CS	6	SPI_CSB
F8	P0.5 / CLK	7	SPI_CLK
B4	P0.6	26	PIO_3
C4	P0.7	25	PIO_6
A2	P1.0 GPIO	23	PIO_2
B3	P1.1 GPIO	24	PIO_5
B2	P1.2 GPIO	27	PIO_8
B1	P1.3 GPIO	22	PIO_9
C2	P1.4 / UART CTS	11	UART_CTS
C3	P1.5 / UART RTS	12	UART_RTS
F2	P1.6 GPIO / UART TXD	13	UART_TX
F3	P1.7 GPIO / UART RXD	14	UART_RX
F4	P2.0 GPIO	19	PIO_14
E1	P2.1 / DD	28	PIO_4
E2	P2.2 / DC	29	PIO_7

CLASSIFICATION	PRODUCT SPECIFICATION	No. DS-17xx-2400-102	REV. 2.0
SUBJECT	CLASS 2 BLUETOOTH LOW ENERGY SINGLE MODE MODULE	PAGE	10 of 35
CUSTOMER'S CODE PAN172x / PAN171x	PANASONIC'S CODE ENW89820AxKF / ENW89835AxKF	DATE	16.12.2013

9. BLUETOOTH FEATURES

- Bluetooth 4.0 single mode low energy technology.
- Class 2 TX power w/o external PA, improving link robustness.
- Excellent link budget (up to 96 dB), enabling long-range applications.
- Accurate digital received signal-strength indicator (RSSI)
- Integrates the new low power profiles and services
- Embedded BT-Stack available

10. PAN172X BLOCK DIAGRAM

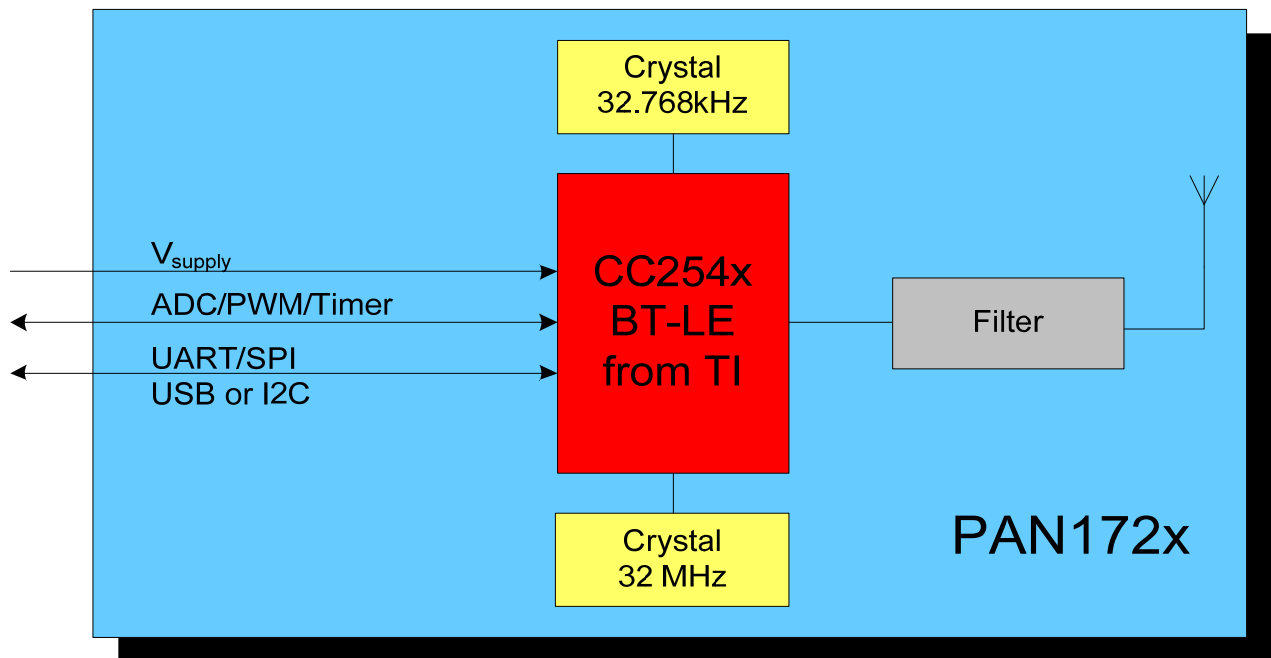

CLASSIFICATION	PRODUCT SPECIFICATION	No. DS-17xx-2400-102	REV. 2.0
SUBJECT	CLASS 2 BLUETOOTH LOW ENERGY SINGLE MODE MODULE	PAGE	11 of 35
CUSTOMER'S CODE PAN172x / PAN171x	PANASONIC'S CODE ENW89820AxKF / ENW89835AxKF	DATE	16.12.2013

11. TEST CONDITIONS

Measurements shall be made under operating free-air temperature range unless otherwise specified.

Temperature	25 ± 10°C
Humidity	40 to 85%RH
Supply Voltage	3.3V

12. GENERAL DEVICE REQUIREMENTS AND OPERATION

All specifications are over temperature and process, unless indicated otherwise.

12.1. ABSOLUTE MAXIMUM RATINGS

No	See ²	Value	Unit
Ratings Over Operating Free-Air Temperature Range			
1	Supply voltage All supply pins must have the same voltage	-0.3 to 3.9	V
2	Voltage on any digital pin	-0.3 to VDD+0.3 <3,9	V
3	Operating ambient temperature range	-40 to 85	°C
4	Storage temperature range	-40 to 125	°C
5	Bluetooth RF inputs	10	dBm
6	ESD: All pads, according to human-body model, JEDEC STD 22, method A114 According to charged-device model, JEDEC STD 22, method C101	1000 500	V

12.2. RECOMMENDED OPERATING CONDITIONS

No	Rating	Min	Max	Unit
1	Power supply voltage	2	3.6	V
2	Maximum ambient operating temperature	-40	85	°C

² Stresses beyond those listed under "absolute maximum ratings" may cause permanent damage to the device. These are stress ratings only and functional operation of the device at these or any other conditions beyond those indicated under "recommended operating conditions" is not implied. Exposure to absolute-maximum-rated conditions for extended periods may affect device reliability.

CLASSIFICATION	PRODUCT SPECIFICATION	No. DS-17xx-2400-102	REV. 2.0
SUBJECT	CLASS 2 BLUETOOTH LOW ENERGY SINGLE MODE MODULE	PAGE	12 of 35
CUSTOMER'S CODE PAN172x / PAN171x	PANASONIC'S CODE ENW89820AxKF / ENW89835AxKF	DATE	16.12.2013

12.3. PAN1720 CURRENT CONSUMPTION

The current consumption is dependant on the user scenario and the setup and timing in the low power modes. The total power consumption can be optimized by adjusting the scan windows and intervals.

Please refer for the latest information for different power modes to the chapter "Electrical Characteristics" in Texas Instruments datasheet, refer to [2]. As indication below are typical values from CC2540 datasheet.

For PAN1721 refer to CC2541 datasheet.

ELECTRICAL CHARACTERISTICS

Measured on Texas Instruments CC2540 EM reference design with $T_A = 25^\circ\text{C}$ and $V_{DD} = 3\text{ V}$

PARAMETER	TEST CONDITIONS	MIN	TYP	MAX	UNIT
I_{core} Core current consumption	Power mode 1. Digital regulator on; 16-MHz RCOSC and 32-MHz crystal oscillator off; 32.768-kHz XOSC, POR, BOD and sleep timer active; RAM and register retention		235		μA
	Power mode 2. Digital regulator off; 16-MHz RCOSC and 32-MHz crystal oscillator off; 32.768-kHz XOSC, POR, and sleep timer active; RAM and register retention		0.9		
	Power mode 3. Digital regulator off; no clocks; POR active; RAM and register retention		0.4		
	Low MCU activity: 32-MHz XOSC running. No radio or peripherals. No flash access, no RAM access.		6.7		mA
I_{peri} Peripheral current consumption (Adds to core current I_{core} for each peripheral unit activated)	Timer 1. Timer running, 32-MHz XOSC used		90		μA
	Timer 2. Timer running, 32-MHz XOSC used		90		μA
	Timer 3. Timer running, 32-MHz XOSC used		60		μA
	Timer 4. Timer running, 32-MHz XOSC used		70		μA
	Sleep timer, including 32.753-kHz RCOSC		0.6		μA
	ADC, when converting		1.2		mA

GENERAL CHARACTERISTICS

Measured on Texas Instruments CC2540 EM reference design with $T_A = 25^\circ\text{C}$ and $V_{DD} = 3\text{ V}$

PARAMETER	TEST CONDITIONS	MIN	TYP	MAX	UNIT
WAKE-UP AND TIMING					
Power mode 1 → Active	Digital regulator on, 16-MHz RCOSC and 32-MHz crystal oscillator off. Start-up of 16-MHz RCOSC		4		μs
Power mode 2 or 3 → Active	Digital regulator off, 16-MHz RCOSC and 32-MHz crystal oscillator off. Start-up of regulator and 16-MHz RCOSC		120		μs
Active → TX or RX	Crystal ESR = 16 Ω . Initially running on 16-MHz RCOSC, with 32-MHz XOSC OFF		410		μs
	With 32-MHz XOSC initially on		160		μs
RX/TX turnaround			150		μs
RADIO PART					
RF frequency range	Programmable in 2-MHz steps	2402		2480	MHz
Data rate and modulation format	1 Mbps, GFSK, 250 kHz deviation				

CLASSIFICATION	PRODUCT SPECIFICATION	No. DS-17xx-2400-102	REV. 2.0
SUBJECT	CLASS 2 BLUETOOTH LOW ENERGY SINGLE MODE MODULE	PAGE	13 of 35
CUSTOMER'S CODE PAN172x / PAN171x	PANASONIC'S CODE ENW89820AxKF / ENW89835AxKF	DATE	16.12.2013

13. BLUETOOTH RF PERFORMANCE

13.1. PAN1720 BLUETOOTH CHARACTERISTICS

No	Characteristics	Condition	Min	Typ	Max	BT Spec	Unit
1	Operation frequency range		2402		2480		MHz
2	Channel spacing			2			MHz
3	Output Power	Maximum setting, measured at single ended 50ohm.		4			dBm
		Minimum setting, measured at single ended 50ohm.		-24			dBm
4	Sensitivity, High Gain Mode	High-gain mode		-93.0		-70	dBm
		Standard mode		-92.5		-70	

13.2. PAN1721 BLUETOOTH CHARACTERISTICS

No	Characteristics	Condition	Min	Typ	Max	BT Spec	Unit
1	Operation frequency range		2402		2480		MHz
2	Channel spacing			2			MHz
3	Output Power	Maximum setting, measured at single ended 50ohm.		0			dBm
		Minimum setting, measured at single ended 50ohm.		-24			dBm
4	Sensitivity, High Gain Mode	High-gain mode		-93.0		-70	dBm
		Standard mode		-92.5		-70	

13.3. PAN17XX SPURIOUS EMISSION

No	Characteristics	Condition	Typ	Max	Unit
1	Spurious emissions	Conducted measurement with a 50-Ω single-ended load. Complies with EN 300 328, EN 300 440 class 2, FCC CFR47, Part 15 and ARIB STD-T-66		-41	dBm

CLASSIFICATION	PRODUCT SPECIFICATION	No. DS-17xx-2400-102	REV. 2.0
SUBJECT	CLASS 2 BLUETOOTH LOW ENERGY SINGLE MODE MODULE	PAGE	14 of 35
CUSTOMER'S CODE PAN172x / PAN171x	PANASONIC'S CODE ENW89820AxKF / ENW89835AxKF	DATE	16.12.2013

14. SOLDERING TEMPERATURE-TIME PROFILE (FOR REFLOW SOLDERING)

14.1. FOR LEAD SOLDER

**Recommended temp. profile
for reflow soldering**

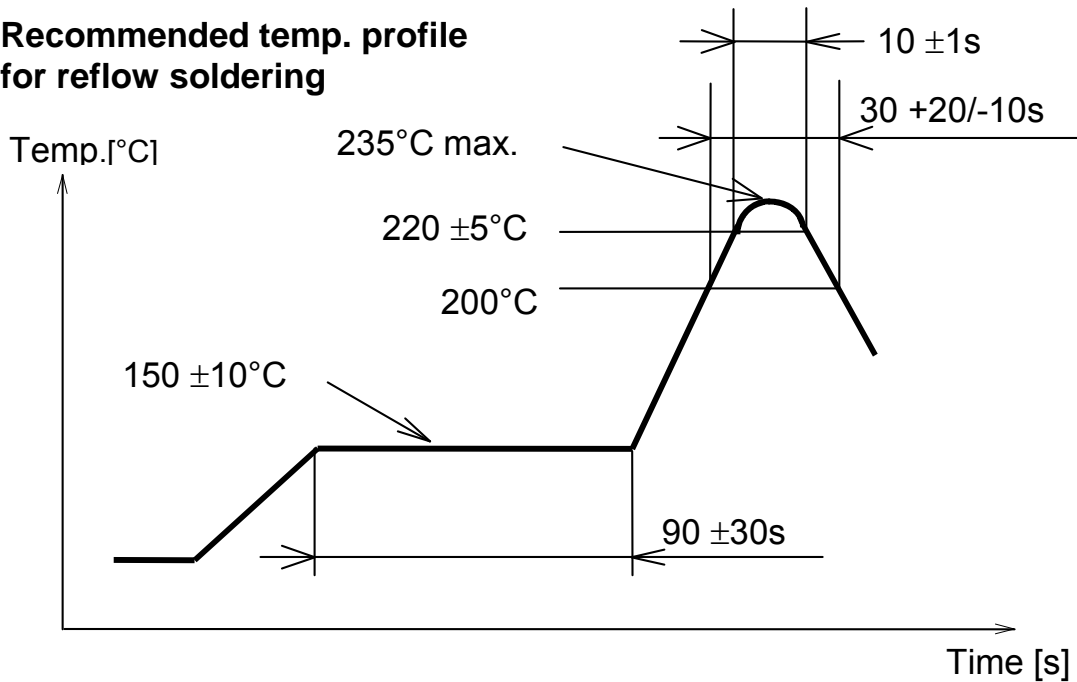

14.2. FOR LEADFREE SOLDER

**Our used temp. profile
for reflow soldering**

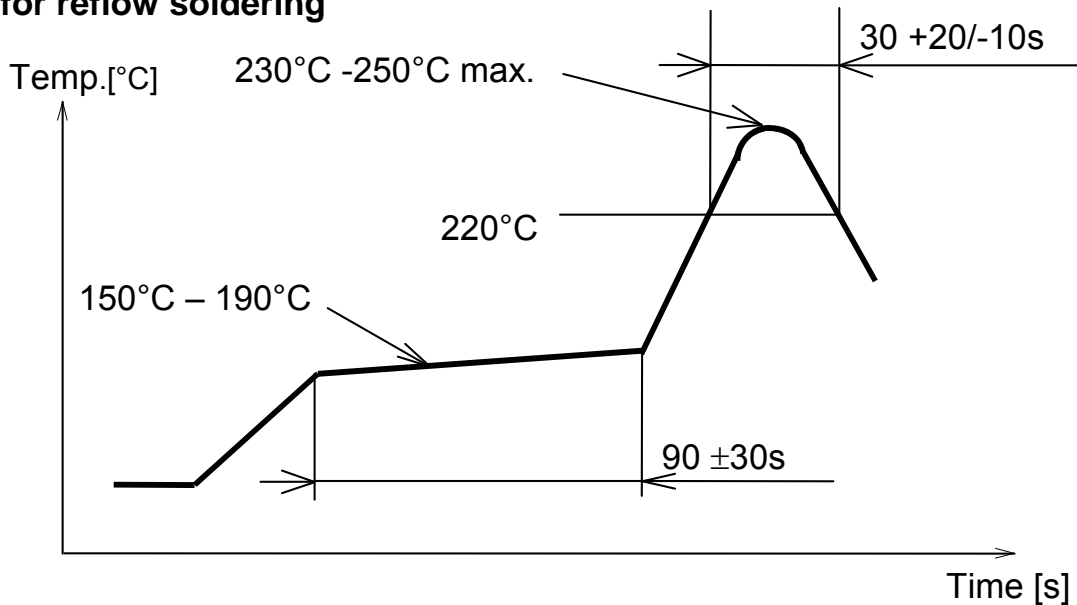

Reflow permissible cycle: 2
Opposite side reflow is prohibited due to module weight.

CLASSIFICATION	PRODUCT SPECIFICATION	No. DS-17xx-2400-102	REV. 2.0
SUBJECT	CLASS 2 BLUETOOTH LOW ENERGY SINGLE MODE MODULE	PAGE	15 of 35
CUSTOMER'S CODE PAN172x / PAN171x	PANASONIC'S CODE ENW89820AxKF / ENW89835AxKF	DATE	16.12.2013

15. PAN172X MODULE DIMENSION

No.	Item	Dimension	Tolerance	Remark
1	Width	8.70	± 0.20	
2	Length	15.60	± 0.20	
3	Height	1.80	± 0.20	With case

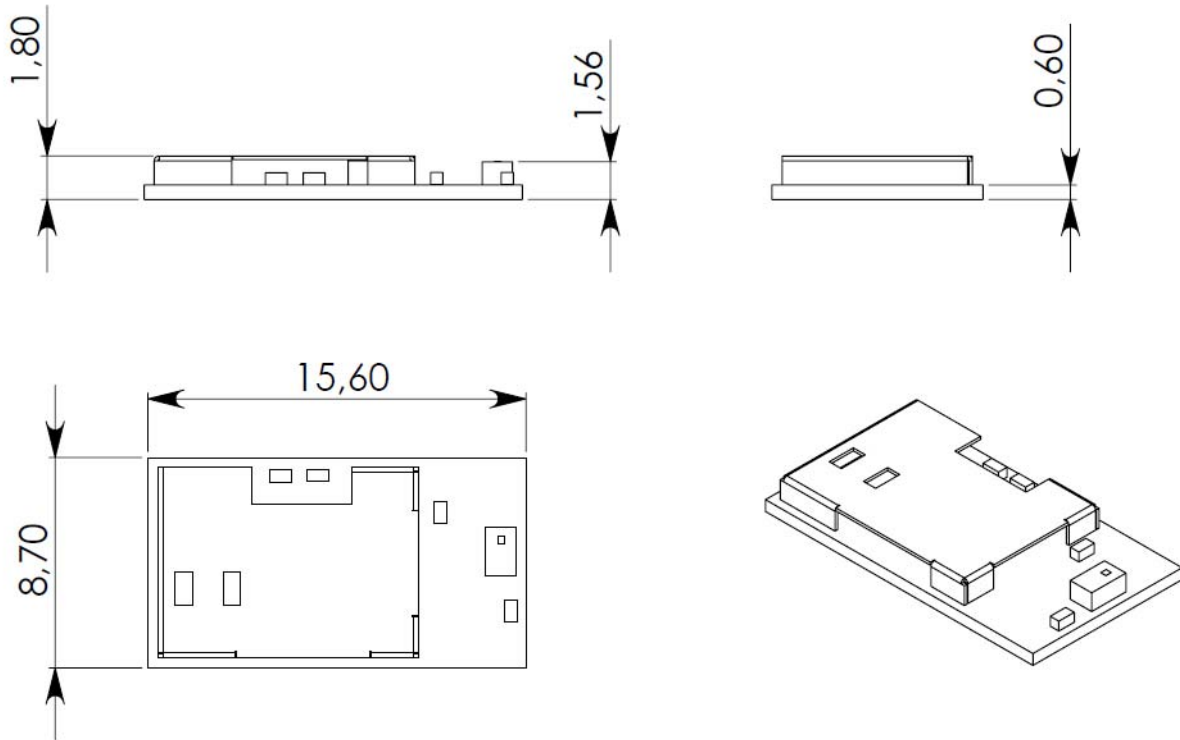

CLASSIFICATION	PRODUCT SPECIFICATION	No. DS-17xx-2400-102	REV. 2.0
SUBJECT	CLASS 2 BLUETOOTH LOW ENERGY SINGLE MODE MODULE	PAGE	16 of 35
CUSTOMER'S CODE PAN172x / PAN171x	PANASONIC'S CODE ENW89820AxKF / ENW89835AxKF	DATE	16.12.2013

16. PAN171X MODULE DIMENSION

No.	Item	Dimension	Tolerance	Remark
1	Width	8.70	± 0.20	
2	Length	11.60	± 0.20	
3	Height	1.80	± 0.20	With case

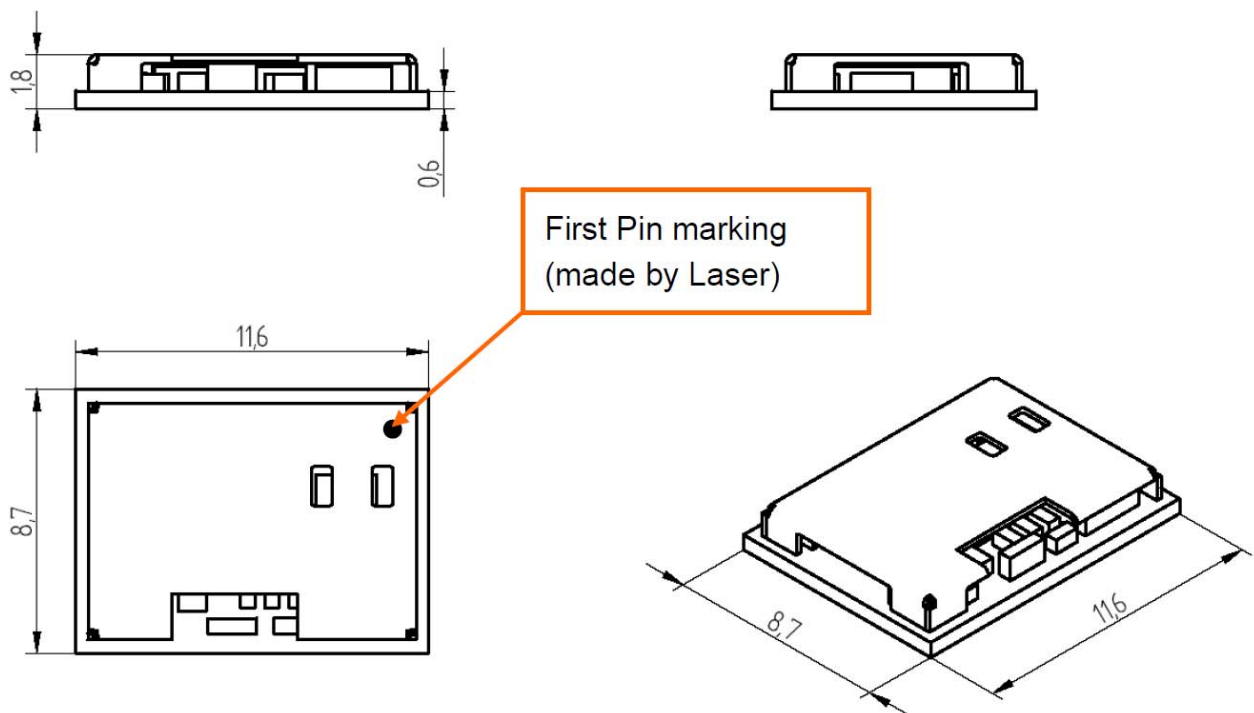

CLASSIFICATION	PRODUCT SPECIFICATION	No. DS-17xx-2400-102	REV. 2.0
SUBJECT	CLASS 2 BLUETOOTH LOW ENERGY SINGLE MODE MODULE	PAGE	17 of 35
CUSTOMER'S CODE PAN172x / PAN171x	PANASONIC'S CODE ENW89820AxKF / ENW89835AxKF	DATE	16.12.2013

17. PAN172X FOOTPRINT OF THE MODULE

All dimensions are in millimeters.
The outer dimensions have a tolerance of $\pm 0.2\text{mm}$.

Top view, Application PCB

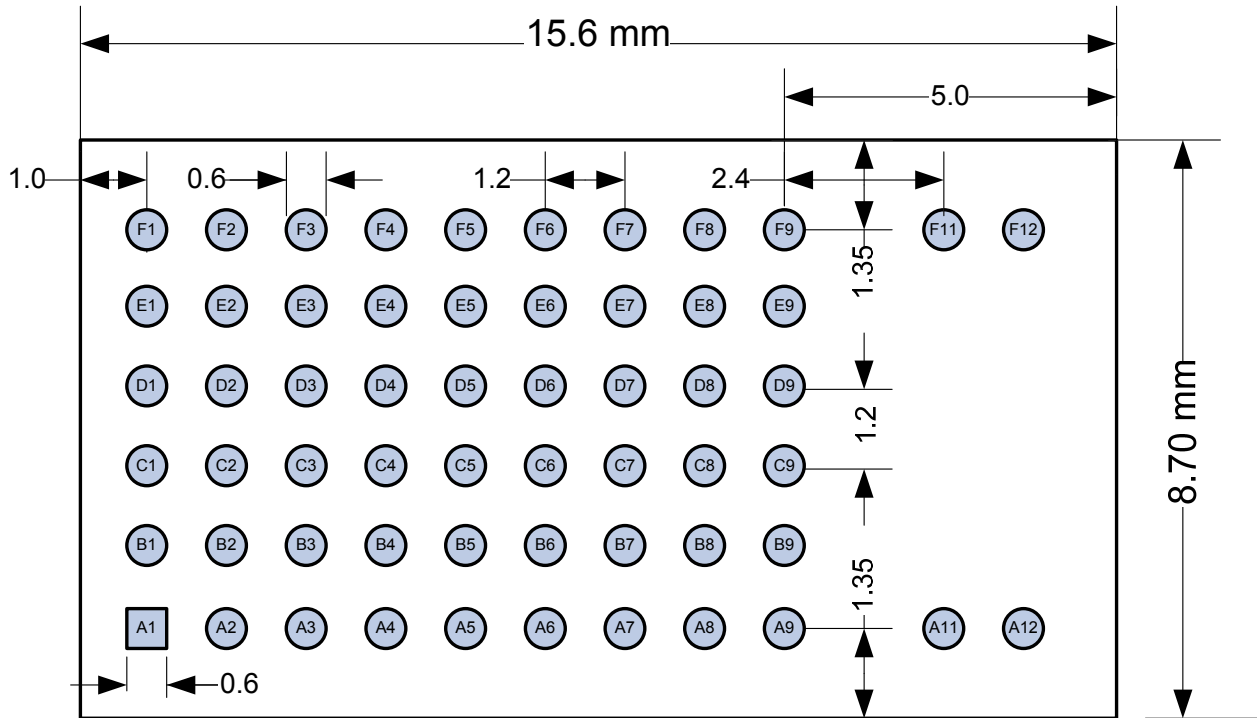

CLASSIFICATION	PRODUCT SPECIFICATION	No. DS-17xx-2400-102	REV. 2.0
SUBJECT	CLASS 2 BLUETOOTH LOW ENERGY SINGLE MODE MODULE	PAGE	18 of 35
CUSTOMER'S CODE PAN172x / PAN171x	PANASONIC'S CODE ENW89820AxKF / ENW89835AxKF	DATE	16.12.2013

18. PAN171X FOOTPRINT OF THE MODULE

All dimensions are in millimeters.
The outer dimensions have a tolerance of $\pm 0.2\text{mm}$.

Top view, Application PCB

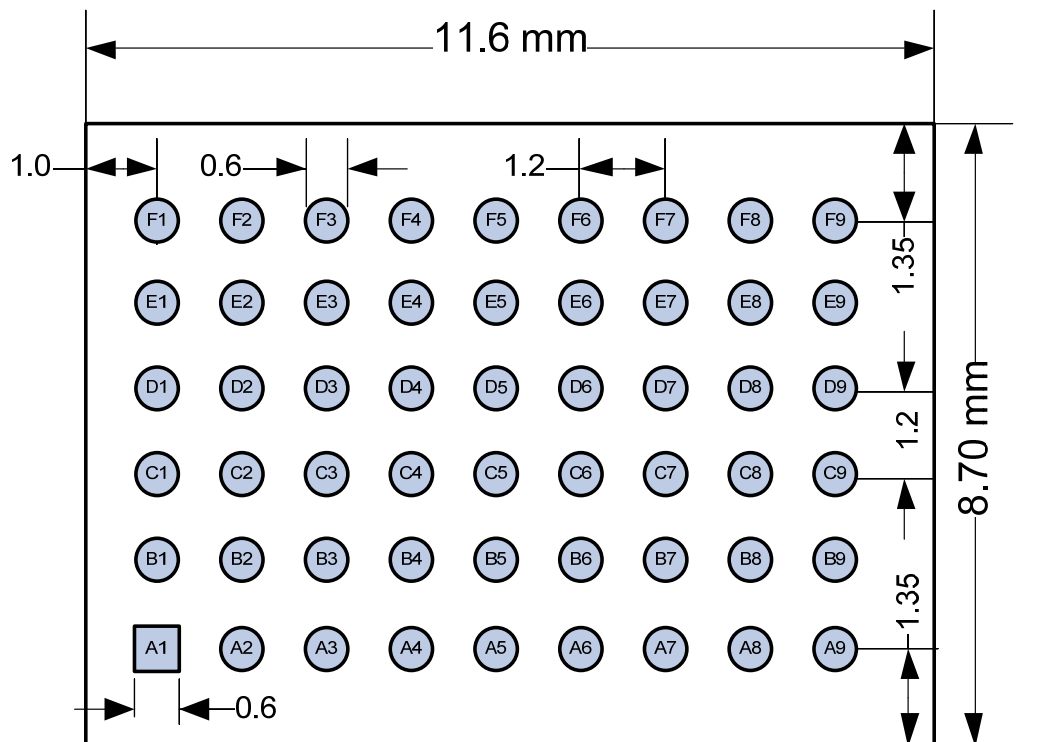

CLASSIFICATION	PRODUCT SPECIFICATION	No. DS-17xx-2400-102	REV. 2.0
SUBJECT	CLASS 2 BLUETOOTH LOW ENERGY SINGLE MODE MODULE	PAGE	19 of 35
CUSTOMER'S CODE PAN172x / PAN171x	PANASONIC'S CODE ENW89820AxKF / ENW89835AxKF	DATE	16.12.2013

19. CASE MARKING

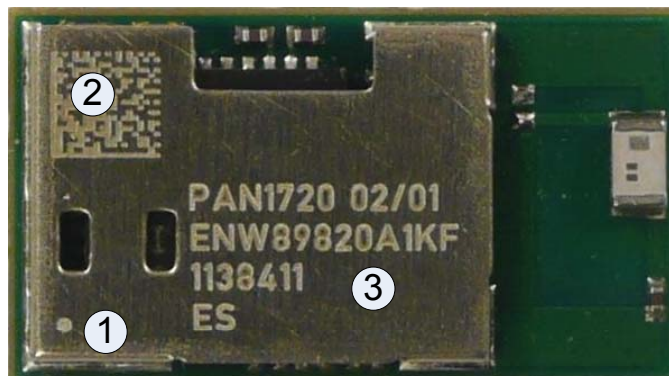

No.	Remark
1	Marking for Pin 1 (Circle 0,15 mm)
2	2D-Code, for internal usage only and can be change without any notice
3	Marking definition see below

19.1. EXAMPLE FOR MARKING

P	A	N	1	7	2	0			H	W	/	S	W				
E	N	W	8	9	8	2	0	A	x	K	F						
Y	Y	W	W	D	L	L											
F	C	C	I	D	:		T	7	V	P	A	N	1	7			

19.2. MARKING DEFINITION

(1) Pin1 marking

(2) 2D code (Serial number)

(3) Marking:

- PAN17xx (Model Name), HW/SW (Hardware/Software version)
- ENW89820AxKF (Part Number, refer to chapter 25 Ordering Information)
- Lot code (YearYear, WeekWeek, Day, LotLot)
- ES (Engineering Sample marking)

Note: For available Software Versions, refer to [1] PAN172xETU Design-Guide. and chapter 25 Ordering Information.

20. MECHANICAL REQUIREMENTS

No.	Item	Limit	Condition
1	Solderability	More than 75% of the soldering area shall be coated by solder	Reflow soldering with recommendable temperature profile
2	Resistance to soldering heat	It shall be satisfied electrical requirements and not be mechanical damage	See chapter 14.2

CLASSIFICATION	PRODUCT SPECIFICATION	No. DS-17xx-2400-102	REV. 2.0
SUBJECT	CLASS 2 BLUETOOTH LOW ENERGY SINGLE MODE MODULE	PAGE	20 of 35
CUSTOMER'S CODE PAN172x / PAN171x	PANASONIC'S CODE ENW89820AxKF / ENW89835AxKF	DATE	16.12.2013

21. DEVELOPMENT OF APPLICATIONS

For development support please refer to [1] PAN172xETU Design-Guide.

22. RELIABILITY TESTS

The measurement should be done after being exposed to room temperature and humidity for 1 hour.

No.	Item	Limit	Condition
1	Vibration test	Electrical parameter should be in specification	a) Freq.:10~50Hz,Amplitude:1.5mm a) 20min. / cycle,1hrs. each of XYZ axis b) Freq.:30~100Hz, 6G b) 20min. / cycle,1hrs. each of XYZ axis
2	Shock test	the same as above	Dropped onto hard wood from height of 50cm for 3 times
3	Heat cycle test	the same as above	-40°C for 30min. and +85°C for 30min.; each temperature 300 cycles
4	Moisture test	the same as above	+60°C, 90% RH, 300h
5	Low temp. test	the same as above	-40°C, 300h
6	High temp. test	the same as above	+85°C, 300h

23. CAUTIONS

Failure to follow the guidelines set forth in this document may result in degrading of the product's functions and damage to the product.

23.1. DESIGN NOTES

- (1) Follow the conditions written in this specification, especially the control signals of this module.
- (2) The supply voltage has to be free of AC ripple voltage (for example from a battery or a low noise regulator output). For noisy supply voltages, provide a decoupling circuit (for example a ferrite in series connection and a bypass capacitor to ground of at least 47uF directly at the module).
- (3) This product should not be mechanically stressed when installed.
- (4) Keep this product away from heat. Heat is the major cause of decreasing the life of these products.
- (5) Avoid assembly and use of the target equipment in conditions where the products' temperature may exceed the maximum tolerance.
- (6) The supply voltage should not be exceedingly high or reversed. It should not carry noise and/or spikes.
- (7) Keep this product away from other high frequency circuits.

CLASSIFICATION	PRODUCT SPECIFICATION	No. DS-17xx-2400-102	REV. 2.0
SUBJECT	CLASS 2 BLUETOOTH LOW ENERGY SINGLE MODE MODULE	PAGE	21 of 35
CUSTOMER'S CODE PAN172x / PAN171x	PANASONIC'S CODE ENW89820AxKF / ENW89835AxKF	DATE	16.12.2013

23.2. INSTALLATION NOTES

- (1) Reflow soldering is possible twice based on the conditions in chapter 15. Set up the temperature at the soldering portion of this product according to this reflow profile.
- (2) Carefully position the products so that their heat will not burn into printed circuit boards or affect the other components that are susceptible to heat.
- (3) Carefully locate these products so that their temperatures will not increase due to the effects of heat generated by neighboring components.
- (4) If a vinyl-covered wire comes into contact with the products, then the cover will melt and generate toxic gas, damaging the insulation. Never allow contact between the cover and these products to occur.
- (5) This product should not be mechanically stressed or vibrated when reflowed.
- (6) To repair the board by hand soldering, follow the conditions set forth in this chapter.
- (7) Do not wash this product.
- (8) Refer to the recommended pattern when designing a board.
- (9) Pressing on parts of the metal cover or fastening objects to the metal will cause damage to the unit.
- (10) For more details on LGA (Land Grid Array) soldering processes refer to the application note.

23.3. USAGE CONDITIONS NOTES

- (1) Take measures to protect the unit against static electricity. If pulses or other transient loads (a large load applied in a short time) are applied to the products, check and evaluate their operation before assembly on the final products.
- (2) Do not use dropped products.
- (3) Do not touch, damage or soil the pins.
- (4) Follow the recommended condition ratings about the power supply applied to this product.
- (5) Electrode peeling strength: Do not add pressure of more than 4.9N when soldered on PCB.
- (6) Pressing on parts of the metal cover or fastening objects to the metal cover will cause damage.
- (7) These products are intended for general purpose and standard use in general electronic equipment, such as home appliances, office equipment, information and communication equipment.

CLASSIFICATION	PRODUCT SPECIFICATION	No. DS-17xx-2400-102	REV. 2.0
SUBJECT	CLASS 2 BLUETOOTH LOW ENERGY SINGLE MODE MODULE	PAGE	22 of 35
CUSTOMER'S CODE PAN172x / PAN171x	PANASONIC'S CODE ENW89820AxKF / ENW89835AxKF	DATE	16.12.2013

23.4. STORAGE NOTES

- (1) The module should not be stressed mechanically during storage.
- (2) Do not store these products in the following conditions or the performance characteristics of the product, such as RF performance will be adversely affected:
 - Storage in salty air or in an environment with a high concentration of corrosive gas, such as Cl₂, H₂S, NH₃, SO₂, or NO_x
 - Storage in direct sunlight
 - Storage in an environment where the temperature may be outside the range of 5°C to 35°C range, or where the humidity may be outside the 45 to 85% range.
 - Storage of the products for more than one year after the date of delivery Storage period: Please check the adhesive strength of the embossed tape and soldering after 6 months of storage.
- (3) Keep this product away from water, poisonous gas and corrosive gas.
- (4) This product should not be stressed or shocked when transported.
- (5) Follow the specification when stacking packed crates (max. 10).

23.5. SAFETY CAUTIONS

These specifications are intended to preserve the quality assurance of products and individual components.

Before use, check and evaluate the operation when mounted on your products. Abide by these specifications, without deviation when using the products. These products may short-circuit. If electrical shocks, smoke, fire, and/or accidents involving human life are anticipated when a short circuit occurs, then provide the following failsafe functions, as a minimum.

- (1) Ensure the safety of the whole system by installing a protection circuit and a protection device.
- (2) Ensure the safety of the whole system by installing a redundant circuit or another system to prevent a single fault causing an unsafe status.

23.6. OTHER CAUTIONS

- (1) This specification sheet is copyrighted. Please do not disclose it to a third party.
- (2) Please do not use the products for other purposes than those listed.
- (3) Be sure to provide an appropriate fail-safe function on your product to prevent an additional damage that may be caused by the abnormal function or the failure of the product.
- (4) This product has been manufactured without any ozone chemical controlled under the Montreal Protocol.
- (5) These products are not intended for other uses, other than under the special conditions shown below. Before using these products under such special conditions, check their performance and reliability under the said special conditions carefully to determine whether or not they can be used in such a manner.
 - In liquid, such as water, salt water, oil, alkali, or organic solvent, or in places where liquid may splash.
 - In direct sunlight, outdoors, or in a dusty environment
 - In an environment where condensation occurs.
 - In an environment with a high concentration of harmful gas (e.g. salty air, HCl,

CLASSIFICATION	PRODUCT SPECIFICATION	No. DS-17xx-2400-102	REV. 2.0
SUBJECT	CLASS 2 BLUETOOTH LOW ENERGY SINGLE MODE MODULE	PAGE	23 of 35
CUSTOMER'S CODE PAN172x / PAN171x	PANASONIC'S CODE ENW89820AxKF / ENW89835AxKF	DATE	16.12.2013

Cl₂, SO₂, H₂S, NH₃, and NO_x)

- (6) If an abnormal voltage is applied due to a problem occurring in other components or circuits, replace these products with new products because they may not be able to provide normal performance even if their electronic characteristics and appearances appear satisfactory.
- (7) When you have any question or uncertainty, contact Panasonic.

CLASSIFICATION	PRODUCT SPECIFICATION	No. DS-17xx-2400-102	REV. 2.0
SUBJECT	CLASS 2 BLUETOOTH LOW ENERGY SINGLE MODE MODULE	PAGE	24 of 35
CUSTOMER'S CODE PAN172x / PAN171x	PANASONIC'S CODE ENW89820AxKF / ENW89835AxKF	DATE	16.12.2013

24. PACKAGING

If the product has mass production status, indicated in chapter 27, we will deliver the module in the package which are described below.

24.1. PAN172X TAPE DIMENSION

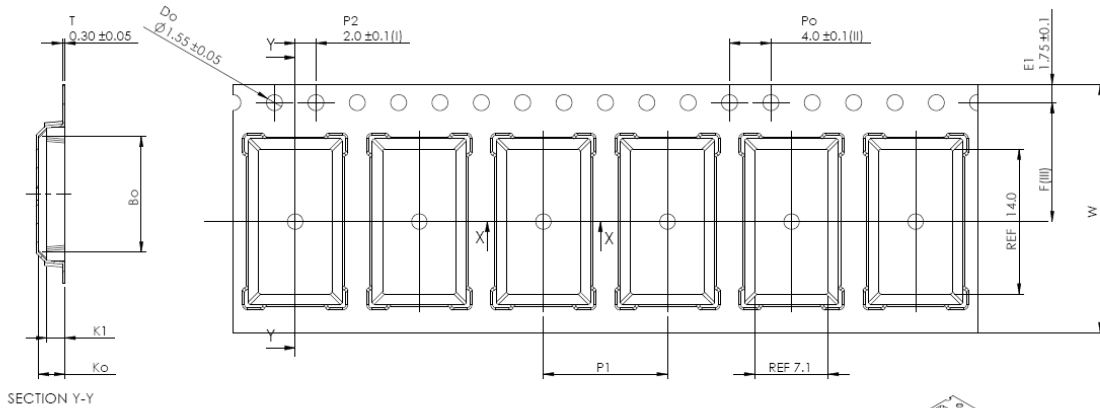

Ao	9.10	+/- 0.1
B0	16.00	+/- 0.1
Ko	3.20	+/- 0.1
K1	2.20	+/- 0.1
F	11.50	+/- 0.1
P1	12.00	+/- 0.1
W	24.00	+/- 0.3

Forming format : Flatbed
Estimated max. length : 64 meter/22B3 reel

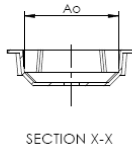

SECTION X-X

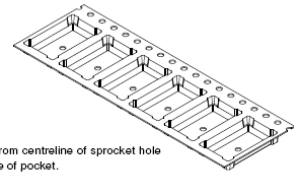

- (I) Measured from centreline of sprocket hole to centreline of pocket.
- (II) Cumulative tolerance of 10 sprocket holes is ± 0.20 .
- (III) Measured from centreline of sprocket hole to centreline of pocket.
- (IV) Other material available.

ALL DIMENSIONS IN MILLIMETRES UNLESS OTHERWISE STATED.

CLASSIFICATION	PRODUCT SPECIFICATION	No. DS-17xx-2400-102	REV. 2.0
SUBJECT	CLASS 2 BLUETOOTH LOW ENERGY SINGLE MODE MODULE	PAGE	25 of 35
CUSTOMER'S CODE PAN172x / PAN171x	PANASONIC'S CODE ENW89820AxKF / ENW89835AxKF	DATE	16.12.2013

24.2. PAN171X TAPE DIMENSION

Ao	9.10	+/-	0.1
Bo	12.00	+/-	0.1
Ko	3.20	+/-	0.1
K1	2.20	+/-	0.1
F	11.50	+/-	0.1
P1	12.00	+/-	0.1
W	24.00	+/-	0.3

SECTION Y-Y

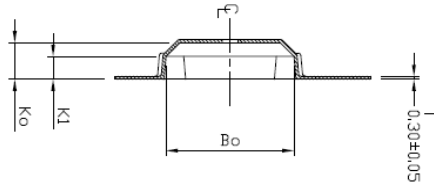

Forming format : Flatbed
Estimated max. length : 65 meter / 2283 reel

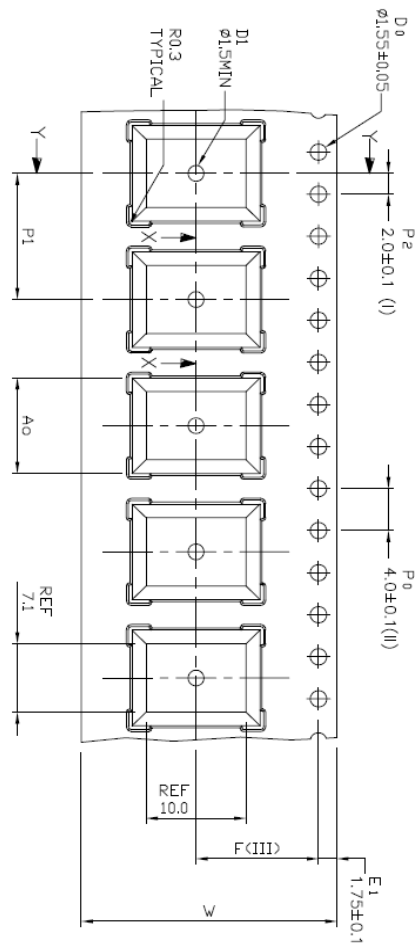
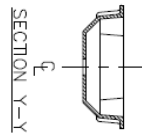

- (I) Measured from centreline of sprocket hole to centreline of pocket.
 - (II) Cumulative tolerance of 10 sprocket holes is ± 0.20 .
 - (III) Measured from centreline of sprocket hole to centreline of pocket.
 - (IV) Other material available.
- ALL DIMENSIONS IN MILLIMETRES UNLESS OTHERWISE STATED.

CLASSIFICATION	PRODUCT SPECIFICATION	No. DS-17xx-2400-102	REV. 2.0
SUBJECT	CLASS 2 BLUETOOTH LOW ENERGY SINGLE MODE MODULE	PAGE	26 of 35
CUSTOMER'S CODE PAN172x / PAN171x	PANASONIC'S CODE ENW89820AxKF / ENW89835AxKF	DATE	16.12.2013

24.3. PACKING IN TAPE

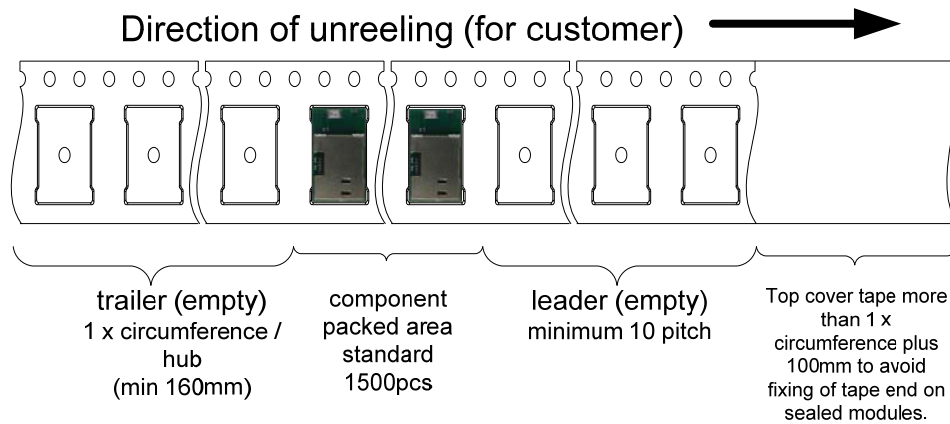

Empty spaces in component packed area shall be less than two per reel and those spaces shall not be consecutive.

Top cover tape shall not be found on reel holes and shall not stick out from reel.

24.4. COMPONENT DIRECTION

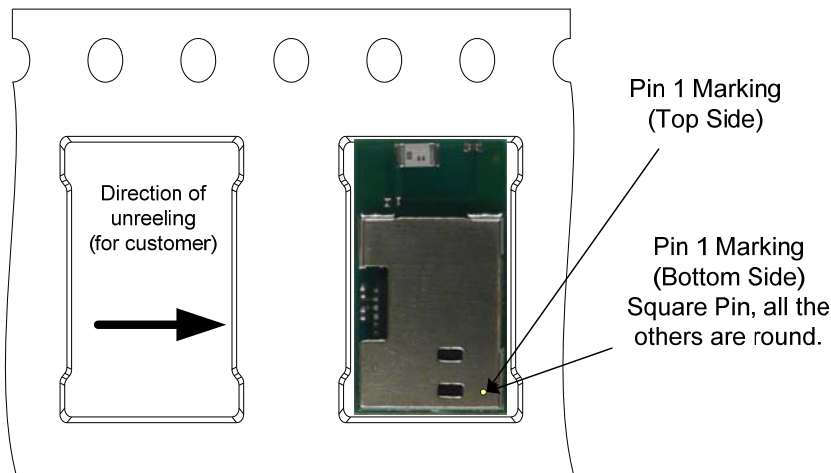

CLASSIFICATION	PRODUCT SPECIFICATION	No. DS-17xx-2400-102	REV. 2.0
SUBJECT	CLASS 2 BLUETOOTH LOW ENERGY SINGLE MODE MODULE	PAGE	27 of 35
CUSTOMER'S CODE PAN172x / PAN171x	PANASONIC'S CODE ENW89820AxKF / ENW89835AxKF	DATE	16.12.2013

24.5. REEL DIMENSION

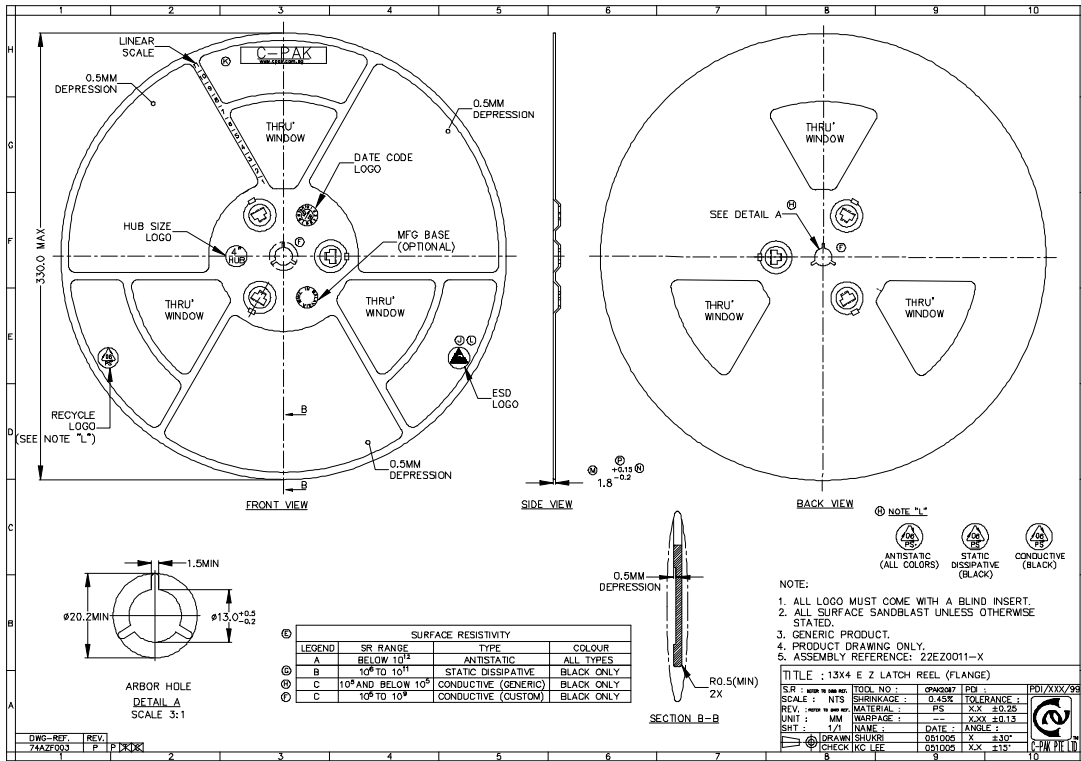

CLASSIFICATION	PRODUCT SPECIFICATION	No. DS-17xx-2400-102	REV. 2.0
SUBJECT	CLASS 2 BLUETOOTH LOW ENERGY SINGLE MODE MODULE	PAGE	28 of 35
CUSTOMER'S CODE PAN172x / PAN171x	PANASONIC'S CODE ENW89820AxKF / ENW89835AxKF	DATE	16.12.2013

24.6. LABEL FOR PACKAGE

The picture shows an example from similar product.

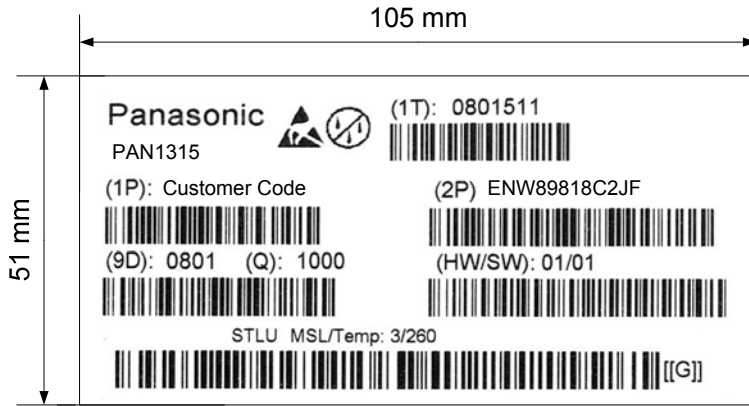

(1T)	Lot code [YYWDDL]	Example from above:
	YY year	printed 08
	WW normal calendar week	printed 01
	D day	printed 5 (Friday)
	L line identifier, if more as one	printed 1
	L lot identifier per day	printed 1
(1P)	Customer Order Code, if any, otherwise company name will be printed	
(2P)	Panasonic Order Code: ENW89820AxKF	
(9D)	Date code as [YYWW]	
(Q)	Quantity [XXXX], variable max. 1500	
(HW/SW)	Hardware /Software Release	
	Hardware01 Indicates the HW revision.	
	Software 01 Indicates the SW revision.	

24.7. TOTAL PACKAGE

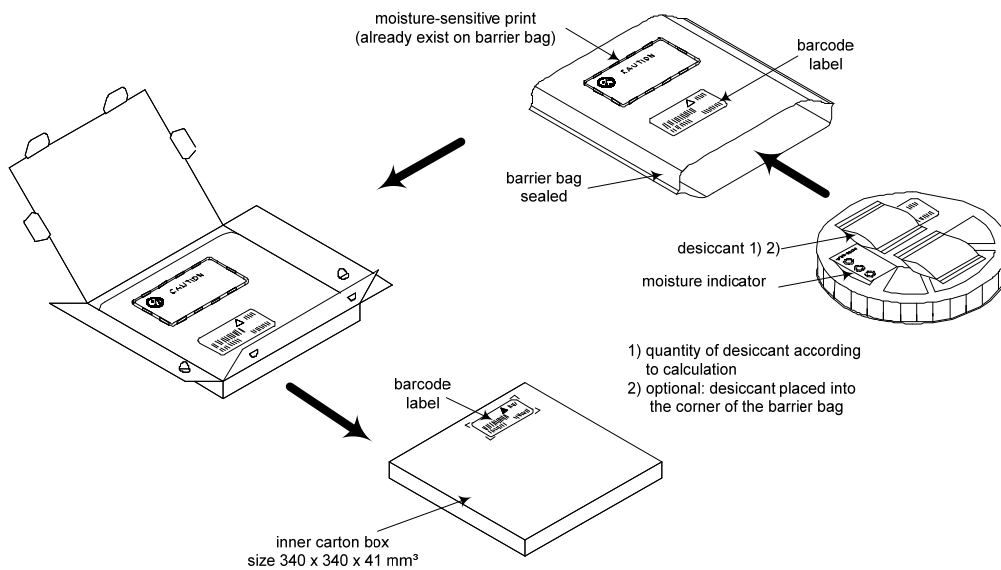

CLASSIFICATION	PRODUCT SPECIFICATION	No. DS-17xx-2400-102	REV. 2.0
SUBJECT	CLASS 2 BLUETOOTH LOW ENERGY SINGLE MODE MODULE	PAGE	29 of 35
CUSTOMER'S CODE PAN172x / PAN171x	PANASONIC'S CODE ENW89820AxKF / ENW89835AxKF	DATE	16.12.2013

25. ORDERING INFORMATION

Ordering part number	Description	MOQ ⁽¹⁾
ENW89820A1KF ⁽²⁾	PAN1720 CLASS 2 Bluetooth single mode Module according BT-4.0. <i>Bluetooth®</i> smart device	1500
ENW89820A3KF ⁽²⁾	PAN1720 Same as above including BlueRadios BR-SPP FW version. <i>Bluetooth®</i> smart device	1500
ENW89835A1KF ⁽²⁾	PAN1721 CLASS 2 Bluetooth single mode Module according BT-4.0. <i>Bluetooth®</i> smart device	1500
ENW89835A3KF ⁽²⁾	PAN1721 Same as above including BlueRadios BR-SPP FW version. <i>Bluetooth®</i> smart device	1500
ENW89835C1KF	PAN1711 CLASS 2 Bluetooth single mode Module according BT-4.0. <i>Bluetooth®</i> smart device without antenna	ES
ENW89835C3KF	PAN1711 Same as above without antenna including BlueRadios BR-SPP FW version. <i>Bluetooth®</i> smart device without antenna	ES

Notes:

- (1) Abbreviation for Minimum Order Quantity (MOQ). The standard MOQ for mass production is 1500 pieces, fewer only on customer demand. Samples for evaluation can be delivered at any quantity via the distribution channels.
- (2) Samples are available on customer demand

25.1. INFORMATION REGARDING SOFTWARE VERSIONS

ENW89820/35A1KF:

The modules will be delivered with an empty flash. Customers need to program their own TI software in the production process. For details refer to the design guide.

ENW89820/35A3KF:

The modules are delivered with BlueRadios nBlue software. This software includes a bootloader and can be updated over the UART. For the latest revision refer to this link:

<http://blueradios.com/panasonic/index.php>

Note: New customers seeking firmware and firmware support are required to register by providing an invoice number.

CLASSIFICATION	PRODUCT SPECIFICATION	No. DS-17xx-2400-102	REV. 2.0
SUBJECT	CLASS 2 BLUETOOTH LOW ENERGY SINGLE MODE MODULE	PAGE	30 of 35
CUSTOMER'S CODE PAN172x / PAN171x	PANASONIC'S CODE ENW89820AxKF / ENW89835AxKF	DATE	16.12.2013

26. ROHS AND REACH DECLARATION

Hereby we declare to our best present knowledge based on declaration of our suppliers that this product follows the latest official RoHS and REACH Directive.

Panasonic

Panasonic Industrial Devices Slovakia s.r.o.
Oravicka 616, 028 01 TRSTENA

Tel: +421(0)43 5303 200
Fax: +421(0)43 5303 207



Dear Customer,

Date: 20.11.2012

Panasonic Industrial Devices Slovakia s.r.o., guarantee that:

Directive 1907/2006 (REACH)

Substances from the candidate lists of so called "substances of very high concern" (SVHC) published by ECHA are regularly monitored if SVHC substances are contained in our products above 0.1% (w/w).

Due to the high complexity of these substance investigations covering all of our global suppliers, this process required some time. We will provide you with all substance information regarding our products based on information collected from our suppliers.

Panasonic Industrial Devices Slovakia s.r.o. hereby declares that all products manufactured and delivered to your company have SVHC substances < 0.1% (w/w).

SVHC Substances:

SVHC Candidate list 1	(28/10/2008)	[15 Substances]
SVHC Candidate list 2	(13/01/2010)	[12 Substances]
SVHC Candidate list 2	(30/03/2010)	[1 Substance]
SVHC Candidate list 3	(18/06/2010)	[8 Substances]
SVHC Candidate list 4	(15/12/2010)	[8 Substances]
SVHC Candidate list 5	(20/06/2011)	[7 Substances]
SVHC Candidate list 6	(19/12/2011)	[20 Substances]
SVHC Candidate list 7	(18/06/2012)	[13 Substances]

Directive 2011/65/EC (RoHS)

We confirm that all products supplied to you including package do not contain the following substances which are banned by Directive 2002/95/EC (RoHS) or if contain a maximum concentration of 0.1% by weight in homogeneous materials for:

- Lead and lead compounds,
- Mercury and mercury compounds,
- Chromium (VI),
- PBB (polybrominated biphenyl) category, PBDE (polybrominated biphenyl ether) category and a maximum concentration of 0.01% by weight in homogeneous materials for:
- Cadmium and cadmium compounds.

Wireless Modules (ENW898series; ENW596series; ENWC9Aseries)

Create:	Kostalikova Alena	Check:	Firmentova Viera	Approval:	Kashiwaya Shinichi
EQ		QA&QC		Managing Director	

For the most updated one, please refer to [4].

CLASSIFICATION	PRODUCT SPECIFICATION	No. DS-17xx-2400-102	REV. 2.0
SUBJECT	CLASS 2 BLUETOOTH LOW ENERGY SINGLE MODE MODULE	PAGE	31 of 35
CUSTOMER'S CODE PAN172x / PAN171x	PANASONIC'S CODE ENW89820AxKF / ENW89835AxKF	DATE	16.12.2013

27. DATA SHEET STATUS

This data sheet contains the final specification (RELEASE).

Panasonic reserves the right to make changes at any time without notice in order to improve design and supply the best possible product.

Please consult the most recently issued data sheet before initiating or completing a design.

Use this URL to search for the most recent version of this data sheet:

[PAN172x Datasheet](#)

28. HISTORY FOR THIS DOCUMENT

Revision	Date	Modification / Remarks
0.01	November 2011	1 st preliminary version.
0.02	November 2011	Deleted footnote in chapter 12.
1.00	April 2012	Released Version.
1.1	July 2012	Add chapter 25.1 Information regarding Software Versions. Link to LGA app note. Removed watermark. UART pinning for BR-SW version. I2C pinning for PAN1721 version. FCC, IC, IDs.
1.2	July 2012	Added remark "top view" for footprint. Corrected FCC ID to T7VPAN17. Change to the correct company name in footer.
1.3	Agust 2012	Change IC text in chapter 32.1 Change to the correct company name in footer. New format for chapter Related Documents
1.4	November 2012	Added some remarks to PAN1721 version. Added non antenna version part number to Ordering information.
1.5	December 2012	Added PAN1711 ES information
1.6	January 2013	Added dimensions and pinout for the non-antenna versions PAN171x.
1.7	January 2013	Minor changes in chapter 6, 31.4. Chapter 3 was included and chapter 34 BT Certification was added.
1.8	May 2013	Changed Block Diagram
1.9	August 2013	Included Crossreference for GPIOs to BlueRadios Pinout
2.0	December 2013	Removed QDID from front page. QDID is described in chapter 33.

29. RELATED DOCUMENTS

For an update, please search in the suitable homepage.

- [1] PAN172xETU Design-Guide
<http://www.pideu.panasonic.de/pdf/168ApplicationNote.pdf>
- [2] Semiconductor Datasheet
[CC2540 from Texas Instruments](#)
[CC2541 from Texas Instruments](#)
- [3] Application Note Land Grid Array
<http://www.pideu.panasonic.de/pdf/184ext.pdf>
- [4] REACH and RoHS Certificate
<http://www.pideu.panasonic.de/pdf/182ext2.jpg>

CLASSIFICATION	PRODUCT SPECIFICATION	No. DS-17xx-2400-102	REV. 2.0
SUBJECT	CLASS 2 BLUETOOTH LOW ENERGY SINGLE MODE MODULE	PAGE	32 of 35
CUSTOMER'S CODE PAN172x / PAN171x	PANASONIC'S CODE ENW89820AxKF / ENW89835AxKF	DATE	16.12.2013

30. GENERAL INFORMATION

© Panasonic Industrial Devices Europe GmbH 2012.

All rights reserved.

This product description does not lodge the claim to be complete and free of mistakes.

Please contact the related product manager in every case.

If we deliver ES samples to the customer, these samples have the status Engineering Samples. This means, the design of this product is not yet concluded. Engineering Samples may be partially or fully functional, and there may be differences to be published Data Sheet.

Engineering Samples are not qualified and are not to be used for reliability testing or series production.

Disclaimer:

Customer acknowledges that samples may deviate from the Data Sheet and may bear defects due to their status of development and the lack of qualification mentioned above.

Panasonic rejects any liability or product warranty for Engineering Samples. In particular, Panasonic disclaims liability for damages caused by

- the use of the Engineering Sample other than for Evaluation Purposes, particularly the installation or integration in an other product to be sold by Customer,
- deviation or lapse in function of Engineering Sample,
- improper use of Engineering Samples.

Panasonic disclaims any liability for consequential and incidental damages.

In case of any questions, please contact your local sales partner or the related product manager.

31. REGULATORY INFORMATION

31.1. FCC NOTICE



The devices PAN17xx, for details refer to Chapter 25, including the antennas, which are listed in 31.5, complies with Part 15 of the FCC Rules. The device meets the requirements for modular transmitter approval as detailed in FCC public Notice DA00-1407.transmitter Operation is subject to the following two conditions: (1) This device may not cause harmful interference, and (2) This device must accept any interference received, including interference that may cause undesired operation.

31.2. CAUTION



The FCC requires the user to be notified that any changes or modifications made to this device that are not expressly approved by Panasonic Industrial Devices Europe GmbH may void the user's authority to operate the equipment.

This equipment has been tested and found to comply with the limits for a Class B digital device, pursuant to Part 15 of the FCC Rules. These limits are designed to provide reasonable protection against harmful interference in a residential installation. This equipment generates, uses and can radiate radio frequency energy and, if not installed and used in accordance with the instructions, may cause harmful interference to radio communications. However, there is no guarantee that interference will not occur in a particular installation. If this equipment does cause harmful interference to radio or television reception, which can be determined by turning the equipment off and on, the user is encouraged to try to correct the interference by one or more of the following measures:

CLASSIFICATION	PRODUCT SPECIFICATION	No. DS-17xx-2400-102	REV. 2.0
SUBJECT	CLASS 2 BLUETOOTH LOW ENERGY SINGLE MODE MODULE	PAGE	33 of 35
CUSTOMER'S CODE PAN172x / PAN171x	PANASONIC'S CODE ENW89820AxKF / ENW89835AxKF	DATE	16.12.2013

- Reorient or relocate the receiving antenna.
- Increase the separation between the equipment and receiver.
- Connect the equipment into an outlet on a circuit different from that to which the receiver is connected.
- Consult the dealer or an experienced radio/TV technician for help

31.3. LABELING REQUIREMENTS



The Original Equipment Manufacturer (OEM) must ensure that FCC labeling requirements are met. This includes a clearly visible label on the outside of the OEM enclosure specifying the appropriate Panasonic FCC identifier for this product as well as the FCC Notice above. The FCC identifier is **FCC ID: T7VPAN17**. This FCC identifier is valid for all PAN17xx modules, for details, see the Chapter 25. Ordering Information.

In any case the end product must be labelled exterior with "Contains FCC ID: T7VPAN17"

31.4. ANTENNA WARNING



For the related part number of PAN17xx refer to Chapter 25. Ordering Information.

This devices are tested with a standard SMA connector and with the antennas listed below. When integrated in the OEMs product, these fixed antennas require installation preventing end-users from replacing them with non-approved antennas. Any antenna not in the following table must be tested to comply with FCC Section 15.203 for unique antenna connectors and Section 15.247 for emissions. The FCC identifier for this device with the antenna listed in item 1 are the same (FCC ID: T7VPAN17).

31.5. APPROVED ANTENNA LIST

Note: We are able to qualify your antenna and will add to this list as that process is completed.

Item	Part Number	Manufacturer	Frequency Band	Type	Gain (dBi)
2	LDA212G3110K	Murata	2.4GHz	Chip-Antenna	+0.9

31.6. RF EXPOSURE PAN17XX



To comply with FCC RF Exposure requirements, the Original Equipment Manufacturer (OEM) must ensure that the approved antenna in the previous table must be installed.

The preceding statement must be included as a CAUTION statement in manuals for products operating with the approved antennas in the previous table to alert users on FCC RF Exposure compliance.

Any notification to the end user of installation or removal instructions about the integrated radio module is not allowed.

The radiated output power of PAN17xx with mounted ceramic antenna (**FCC ID: T7VPAN17**) is far below the FCC radio frequency exposure limits. Nevertheless, the PAN17xx shall be used in such a manner that the potential for human contact during normal operation is minimized.

End users may not be provided with the module installation instructions. OEM integrators and end users must be provided with transmitter operating conditions for satisfying RF exposure compliance.

CLASSIFICATION	PRODUCT SPECIFICATION	No. DS-17xx-2400-102	REV. 2.0
SUBJECT	CLASS 2 BLUETOOTH LOW ENERGY SINGLE MODE MODULE	PAGE	34 of 35
CUSTOMER'S CODE PAN172x / PAN171x	PANASONIC'S CODE ENW89820AxKF / ENW89835AxKF	DATE	16.12.2013

32. INDUSTRY CANADA CERTIFICATION

PAN17xx is licensed to meet the regulatory requirements of Industry Canada (IC),
license: IC: 216Q-PAN17

Manufacturers of mobile, fixed or portable devices incorporating this module are advised to clarify any regulatory questions and ensure compliance for SAR and/or RF exposure limits. Users can obtain Canadian information on RF exposure and compliance from www.ic.gc.ca.

This device has been designed to operate with the antennas listed in Table 20 above, having a maximum gain of 0.9 dBi. Antennas not included in this list or having a gain greater than 0.9 dBi are strictly prohibited for use with this device. The required antenna impedance is 50 ohms. The antenna used for this transmitter must not be co-located or operating in conjunction with any other antenna or transmitter.

Due to the model size the IC identifier is displayed in the installation instruction only and can not be displayed on the modules label due to the limited size (8.7x15.6mm).

32.1. IC NOTICE



The devices PAN17xx, for details refer to Chapter 25, including the antennas, which are listed in 31.5, complies with Canada RSS-GEN Rules. The device meets the requirements for modular transmitter approval as detailed in RSS-GEN. Operation is subject to the following two conditions: (1) This device may not cause harmful interference, and (2) This device must accept any interference received, including interference that may cause undesired operation.

32.2. LABELING REQUIREMENTS



The Original Equipment Manufacturer (OEM) must ensure that IC labeling requirements are met. This includes a clearly visible label on the outside of the OEM enclosure specifying the appropriate Panasonic IC identifier for this product as well as the IC Notice above. The IC identifier is 216Q-PAN17. This IC identifier is valid for all PAN17xx modules, for details, see the Chapter 25. Ordering Information.

In any case the end product must be labelled exterior with "Contains IC: 216Q-PAN17"

33. BLUETOOTH CERTIFICATION

The Design is listed as Controller Subsystem with QDID: B016552
https://www.bluetooth.org/tpg/EPL_Detail.cfm?ProductID=22941

The module is listed as EPL based on Texas Instruments QDID B016552.

To create an EPL, two Subsystems e.g. QDID: B016552 and QDID: B017183 (software stack) need to be combined.

CLASSIFICATION	PRODUCT SPECIFICATION	No. DS-17xx-2400-102	REV. 2.0
SUBJECT	CLASS 2 BLUETOOTH LOW ENERGY SINGLE MODE MODULE	PAGE	35 of 35
CUSTOMER'S CODE PAN172x / PAN171x	PANASONIC'S CODE ENW89820AxKF / ENW89835AxKF	DATE	16.12.2013

34. EUROPEAN R&TTE DECLARATION OF CONFORMITY

Hereby, Panasonic Industrial Devices Europe GmbH, declares that the Bluetooth module PAN17xx and their versions is in compliance with the essential requirements and other relevant provisions of Directive 1999/5/EC. As a result of the conformity assessment procedure described in Annex III of the Directive 1999/5/EC, the end-customer equipment should be labelled as follows:



PAN17xx and their versions in the specified reference design can be used in the following countries: Austria, Belgium, Cyprus, Czech Republic, Denmark, Estonia, Finland, France, Germany, Greece, Hungary, Ireland, Italy, Latvia, Lithuania, Luxembourg, Malta, Poland, Portugal, Slovakia, Slovenia, Spain, Sweden, The Netherlands, the United Kingdom, Switzerland, and Norway.

35. LIFE SUPPORT POLICY

This Panasonic product is not designed for use in life support appliances, devices, or systems where malfunction can reasonably be expected to result in a significant personal injury to the user, or as a critical component in any life support device or system whose failure to perform can be reasonably expected to cause the failure of the life support device or system, or to affect its safety or effectiveness. Panasonic customers using or selling these products for use in such applications do so at their own risk and agree to fully indemnify Panasonic for any damages resulting.