

# SPECIFICATION FOR APPROVAL

REF. :

PROD. NAME	Shielded SMD Power Inductor	ABC'S DWG NO.		HP0603□□□□2□-□□□	
		REV.	20160323-G	PAGE	1

## I . Configuration and dimensions :

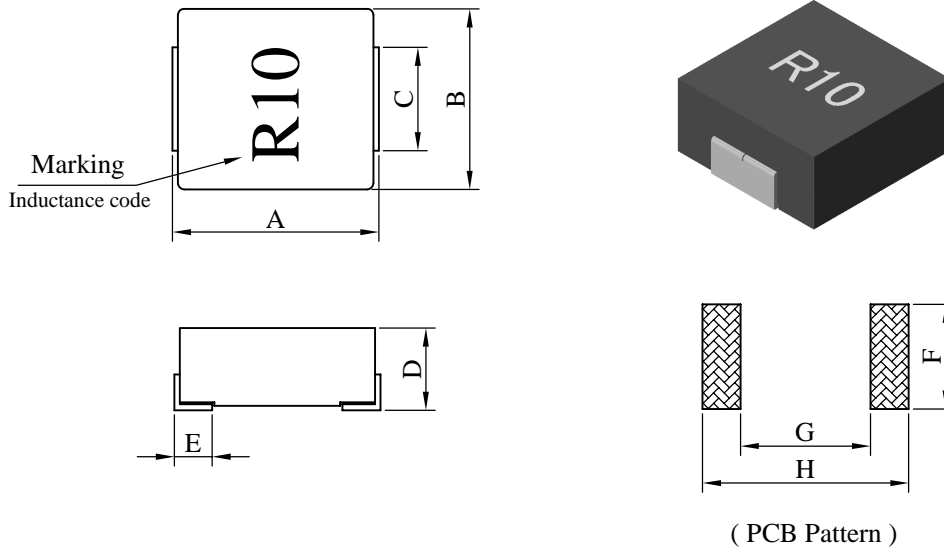

Unit : m/m

A	B	C	D	E	F	G	H
7.20 ±0.30	6.50 ±0.20	3.00 ±0.30	3.00 max.	1.70 ±0.50	3.40 typ.	3.70 typ.	7.40 typ.

## II . Description :

- a . Powder molding construction.
- b . Magnetically shielded.
- c . Enamelled copper wire : H class
- d . Product weight : 0.80g ( ref. )
- e . Moisture sensitivity Level 2a
- f . Products comply with RoHS' requirements
- g . Halogen free available

## III . General specification :

- a . Storage temp. : -55°C ----+125°C
- b . Operating temp. : -55°C ----+125°C  
( Temp. rise included )
- c . Resistance to solder heat : 250°C .10 secs.

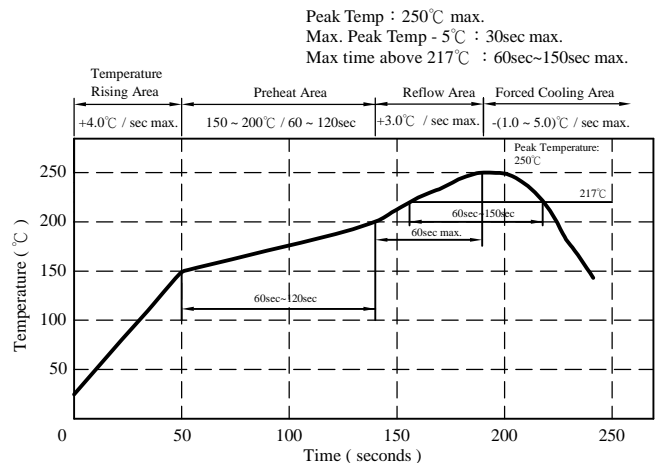

AR-001C

# SPECIFICATION FOR APPROVAL

REF. :

PROD. NAME	Shielded SMD Power Inductor	ABC'S DWG NO.	HP0603□□□□2□-□□□		
		REV.	20160323-G	PAGE	2

IV . Electrical characteristics :

DWG No.	Inductance L ( $\mu$ H )	Isat(A) typ.	Irms(A) typ.	RDC ( $m\Omega$ )	
				max.	typ.
HP0603R10M2□-□□□	0.10±20%	60.0	32.0	2.0	1.5
HP0603R15M2□-□□□	0.15±20%	52.0	26.0	2.5	2.0
HP0603R22M2□-□□□	0.22±20%	40.0	23.0	3.0	2.5
HP0603R33M2□-□□□	0.33±20%	30.0	20.0	4.0	3.5
HP0603R47M2□-□□□	0.47±20%	26.0	17.0	4.5	4.0
HP0603R56M2□-□□□	0.56±20%	19.0	16.0	5.5	5.0
HP0603R68M2□-□□□	0.68±20%	25.0	15.0	5.5	5.0
HP0603R82M2□-□□□	0.82±20%	24.0	13.0	8.0	7.0
HP06031R0M2□-□□□	1.00±20%	22.0	11.0	10.0	9.0
HP06031R5M2□-□□□	1.50±20%	18.0	9.0	15.0	14.0
HP06032R2M2□-□□□	2.20±20%	14.0	8.0	20.0	18.0
HP06033R3M2□-□□□	3.30±20%	13.5	6.0	30.0	28.0
HP06034R7M2□-□□□	4.70±20%	10.0	5.5	40.0	37.0
HP06036R8M2□-□□□	6.80±20%	8.0	4.5	60.0	54.0
HP06038R2M2□-□□□	8.20±20%	7.5	4.0	68.0	64.0
HP0603100M2□-□□□	10.00±20%	7.0	3.0	105.0	102.0

- 1). □ : Packaging information : □ Code
- 2). "-□□□" : Reference code
- 3). Measured frequency of inductance is 100 kHz / 0.25V
- 4). Isat base on inductance drop 20% typ. of L value at 20°C
- 5). Irms base on temp. rise 40°C typ.

# SPECIFICATION FOR APPROVAL

REF. :

PROD. NAME	Shielded SMD Power Inductor	ABC'S DWG NO.	HP0603□□□□2□-□□□		
		REV.	20160323-G	PAGE	3

## V . Packaging information :

### (1) Configuration

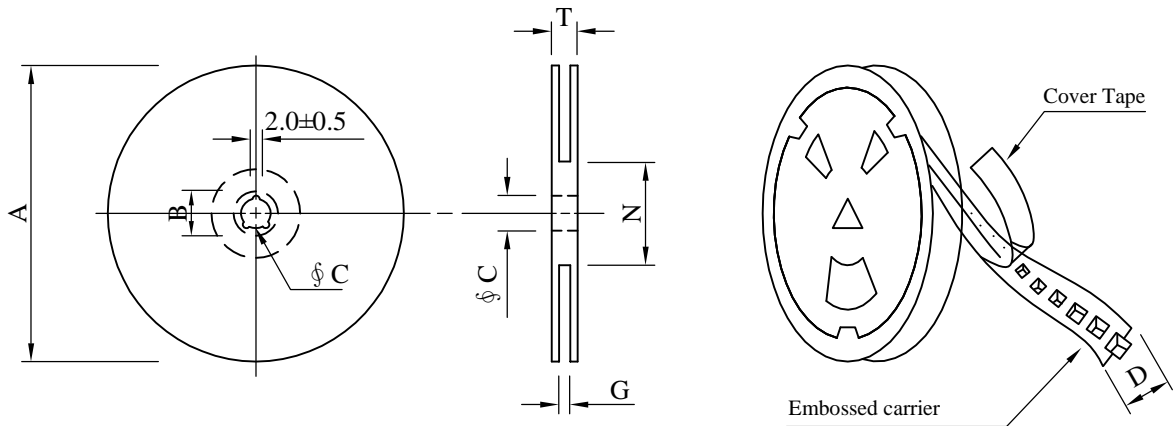

※Carrier tape width : D

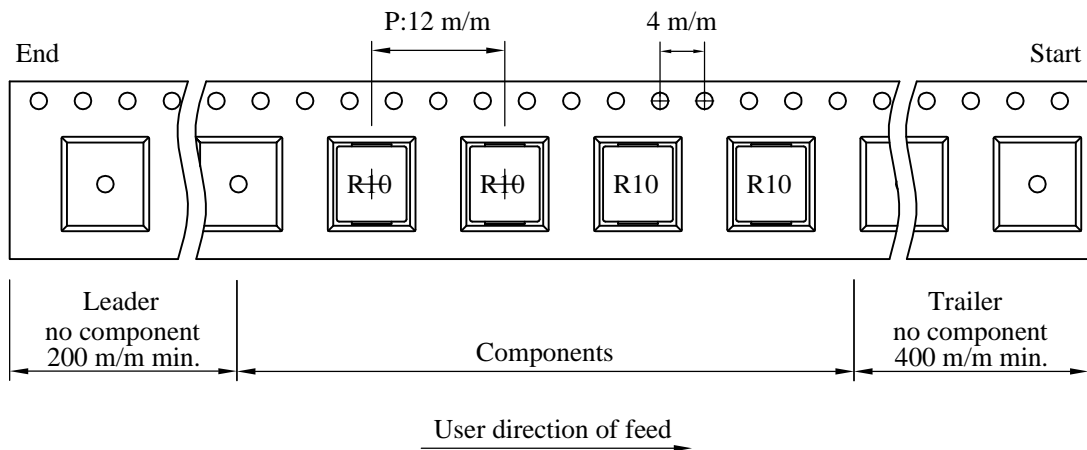

### (2) Dimensions

Unit:m/m

Style	A	B	C	D	G	N	T
13 - 16	330	21±0.8	13±0.5	16	18 <sup>+0</sup>	50 <sup>-0</sup>	22.4

### (3) Q'TY & G.W. Per package

Code	Inner : Reel			Outer : Carton		
	Q'TY (pcs)	G.W. (gw)	Style	Q'TY (pcs)	G.W. (Kg)	Size (cm)
B	1,500	1,250	13 - 16	9,000	8.00	38 x 37 x 22

AR-001C

# SPECIFICATION FOR APPROVAL

REF. :

<b>PROD. NAME</b>	Shielded SMD Power Inductor	<b>ABC'S DWG NO.</b>	HP0603□□□□2□-□□□		
		<b>REV.</b>	20160323-G	<b>PAGE</b>	4

## VI . Reliability test :

Item	Reference documents	Test Condition	Test Specification
1.High Temperature Exposure	MIL-STD-202 Method 108	1.Temperature: 125±2℃ 2.Time:96±2 hours.	1.No mechanical or electrical damage. 2.Inductance shall not change more than ±20%.
2.Temperature Cycling	JESD22-A 104	1.Temperature: -55℃ ~ +125℃ 2.Number of cycle:100 cycle 3.Dwell time:30 minutes	1.No mechanical or electrical damage. 2.Inductance shall not change more than ±20%.
3.Biased Humidity Test	MIL-STD-202 Method 103	1.Temperature : 85±2 ℃ 2.Humidity: 85% RH. 3.Time:96±2 Hours	1.No mechanical or electrical damage. 2.Inductance shall not change more than ±20%.
4.Operational Life	JESD22-A 108	1.Temperature: 125℃ (Temp. rise included) 2.Time:96±2 hours. 3.Rated current	1.No mechanical or electrical damage. 2.Inductance shall not change more than ±20%.
5.External Visual	JESD22-B 101 & MIL-STD-883 Method 2009	Inspect product constructions, marking and workmanship.	1.No pollution on the surface of products. 2.Clear marking. 3.No crack.
6.Physical Dimensions	JESD22-B 100	Verify physical dimensions to the applicable product detail specification.	Per product specification standard
7.Resistance to solvents	MIL-STD-202 Method 215	Immerse into solvent for 3±0.5 minutes & brush 10 times for 3 cycles.	1.No body change in appearance. 2.No marking blurred. 3.Inductance shall not change more than ±20%.
8.Vibration Test	MIL-STD-202 Method 204	1.Frequency and Amplitued : 10-2000-10 Hz, 1.5 mm. 2.Direction:X, Y, Z 3.Test duration:2 hours for each direction, 6 hours in total.	1.No mechanical or electrical damage. 2.Inductance shall not change more than ±20%.
9.Resistance To Soldering Heat Test	MIL-STD-202 Method 210 & J-STD020D.1	1.Highest temperature : 250±5℃. 2.Time ( temp. ≥ 217℃ ) : 60~150 Second. 3.IR reflow times : 3 times.	1.No mechanical or electrical damage. 2.Inductance shall not change more than ±20%.
10.Saturation Current	JIS C 6436 & User SPEC.	1.Applied rated current for 5 second. 2.Saturation current	Inductance shall not drop more than 20% typ.
11.Over load	JIS C 6436 & User SPEC.	1.Applied one and half rated current for a period of 5 minutes. 2.Rated current	No electrical or mechanical damage
12.Temperature Rise Current	JIS C 6436 & User SPEC.	1.Applied rated current for 10 minutes. 2.Temperature measure by digital surface thermometer. 3.Irms current	Surface temperature rise is less than 40℃ typ.
13.Solderability Test	J-STD-002 & JESD22-B 102	1.Baking in pre-testing : 150±5℃ / 16Hours±30 min. 2.Peak temperature : 240±5℃ 3.Time ( temp. ≥ 217℃ ) : 60~150 second. 4.IR reflow times : 1 times.	More than 95% soldering coverage min on terminations.
14.Electrical Characteriazation	MIL-STD-202 Method 304 & User SPEC.	1.Operating temperature : -55℃~125℃ 2.Room temperature : 25℃.	1.No mechanical or electrical damage. 2.Inductance shall not change more than ±20%.
15.Drop	CNS-C6354 & GB/T 2423.8	1.Products shall be mounted on SPEC. PCB and dropped down from a height of 1m 2.Drop total time : 6 time (Every side of sample drop 2 time)	1. Adhesion on PCB shall be enough. 2. Product appearance shall not break. 3. No electrical damage.
16.Terminal Strength Test	IEC 60068-2-21	1.Apply push force to samples mounted on PCB. 2.Force of 1.8 kg for 60±1 seconds.	After test, inductors shall be no mechanical damage.

AR-001C